

Series DS-2 Dry-Type Sprinklers 11.2K Pendent Standard and Quick Response, Standard Coverage

General Description

TYCO Series DS-2 Dry-Type Sprinklers, 11.2K Pendent, Standard (5 mm bulb) and Quick Response (3 mm bulb), and Standard Coverage are decorative glass bulb automatic sprinklers typically used where:

- pendent sprinklers are required on dry pipe systems that are exposed to freezing temperatures (e.g., sprinkler drops from unheated portions of buildings)
- sprinklers and/or a portion of the connecting piping may be exposed to freezing temperatures (e.g., sprinkler drops from wet systems into freezers)

NOTICE

Series DS-2 Dry-Type Sprinklers described herein must be installed and maintained in compliance with this document, as well as with the applicable standards of the National Fire Protection Association (NFPA), in addition to the standards of any other authorities having jurisdiction. Failure to do so may impair the performance of these devices.

The owner is responsible for maintaining their fire protection system and devices in proper operating condition. Contact the installing contractor or product manufacturer with any questions.

Series DS-2 Dry-Type Sprinklers must only be installed in fittings that meet the requirements of the Design Criteria section.

IMPORTANT

Always refer to Technical Data Sheet TFP700 for the "INSTALLER WARNING" that provides cautions with respect to handling and installation of sprinkler systems and components. Improper handling and installation can permanently damage a sprinkler system or its components and cause the sprinkler to fail to operate in a fire situation or cause it to operate prematurely.

Sprinkler Identification Numbers (SINs)

TY5255 – Standard Response
TY5235 – Quick Response

Technical Data

Approvals

UL and C-UL Listed
NYC Approved under MEA 173-02-E

Refer to Table A.

Maximum Working Pressure
175 psi (12,1 bar)

Inlet Thread Connections

1 Inch NPT
ISO 7-R 1

Discharge Coefficient

Refer to Table C.

Temperature Ratings

Refer to Table A.

Finishes

Sprinkler: Refer to Table D.
Escutcheon: Refer to Table D.

Physical Characteristics

| | |
|-------------------------------------|------------------------------|
| Inlet..... | Copper |
| Plug | Copper |
| Yoke..... | Stainless Steel |
| Casing | Galvanized Carbon Steel |
| Insert..... | Bronze |
| Bulb Seat..... | Bronze |
| Bulb | Glass |
| Compression Screw | Bronze |
| Deflector..... | Bronze |
| Frame | Bronze |
| Guide Tube | Stainless Steel |
| Water Tube | Stainless Steel |
| Spring..... | Stainless Steel |
| Gasketed Spring Plate Seal | Beryllium Nickel w/TEFLON |
| Pin | Stainless Steel |
| Button Spring..... | Stainless Steel |
| Escutcheon | Carbon Steel |



Operation

When TYCO Series DS-2 Dry-Type Sprinklers, 11.2K Pendent, Standard (5 mm bulb) and Quick Response (3 mm bulb), and Standard Coverage are in service, water is prevented from entering the assembly by the Plug with Gasketed Spring Plate Seal (Ref. Figure 1) in the Inlet of the sprinkler.

The glass bulb contains a fluid that expands when exposed to heat. When the rated temperature is reached, the fluid expands sufficiently to shatter the glass bulb, and the Bulb Seat is released.

The compressed Spring is then able to expand and push the Water Tube as well as the Guide Tube outward. This action simultaneously pulls inward on the Yoke, withdrawing the Plug with Gasketed Spring Plate Seal from the Inlet, allowing the sprinkler to activate and flow water.

| | | | | |
|---|------------------------|--|-----------------------|---------------------|
| Temperature Rating | Bulb Color Code | TY5255 Standard Response TY5235 Quick Response with Flush Escutcheon (Figure 2) with Recessed Escutcheon (Figure 3) with Extended Escutcheon (Figure 4) without Escutcheon (Figure 5) | | |
| | | SPRINKLER FINISH | | |
| | | Natural Brass | Chromed Plated | Signal White |
| 135°F (57°C) | Orange | 1, 2, 3 | | |
| 155°F (68°C) | Red | | | |
| 175°F (79°C) | Yellow | | | |
| 200°F (93°C) | Green | | | |
| 286°F (141°C) | Blue | | | |
| Notes: 1. Listed by Underwriters Laboratories, Inc. (UL), maximum order length of 48 inches 2. Listed by Underwriters Laboratories for use in Canada (C-UL), maximum order length of 48 inches 3. Approved by the City of New York under MEA 173-02-E <p style="text-align: center;">TABLE A SERIES DS-2 STANDARD & QUICK RESPONSE, STANDARD COVERAGE DRY-TYPE PENDENT SPRINKLERS LABORATORY LISTINGS AND APPROVALS</p> | | | | |

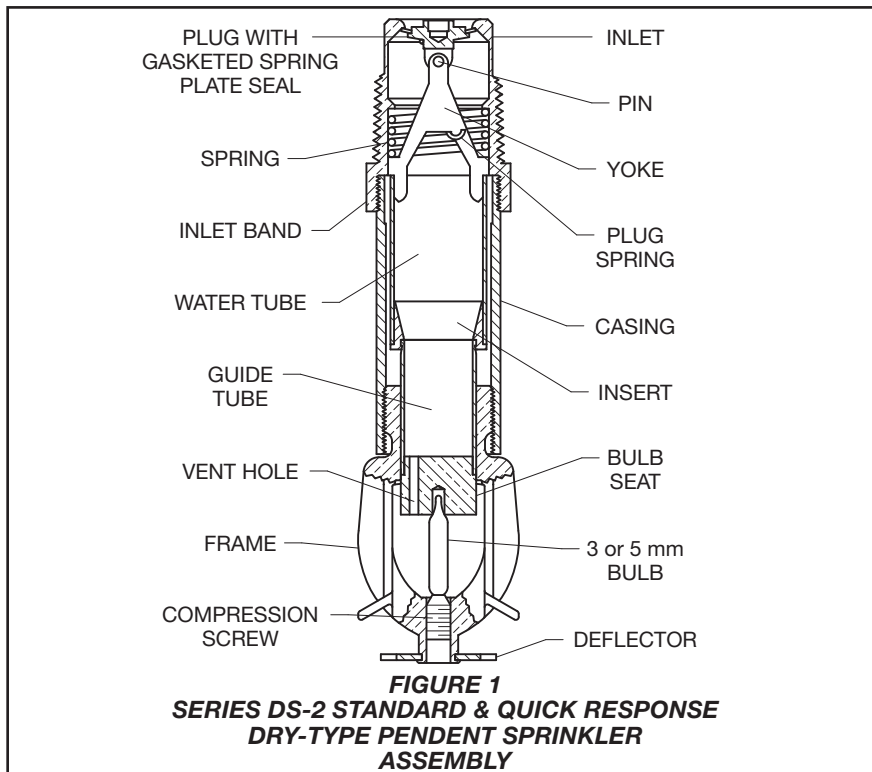

Design Criteria

TYCO Series DS-2 Dry-Type Sprinklers, 11.2K Pendent, Standard (5 mm bulb) and Quick Response (3 mm bulb), and Standard Coverage are intended for use in fire sprinkler systems designed in accordance with the standard coverage installation rules recognized by the applicable listing agency (e.g., UL Listing is based on NFPA 13 requirements).

Sprinkler Fittings

Install 1 inch NPT Series DS-2 Dry-Type Sprinklers in the 1 inch NPT outlet or run of the following fittings:

- malleable or ductile iron threaded tee fittings that meet the dimensional requirements of ANSI B16.3 (Class 150)
- cast iron threaded tee fittings that meet the dimensional requirements of ANSI B16.4 (Class 125)

Do not install Series DS-2 Dry-Type Sprinklers into elbow fittings. The Inlet of the sprinkler can contact the interior of the elbow.

The unused outlet of the threaded tee is plugged as shown in Figure 9.

You can also install Series DS-2 Dry-Type Sprinklers in the 1 inch NPT outlet of a GRINNELL Figure 730 Mechanical Tee. However, the use of the Figure 730 Tee for this arrangement is limited to wet pipe systems.

The configuration shown in Figure 8 is only applicable for wet pipe systems where the sprinkler fitting and water-filled pipe above the sprinkler fitting are not subject to freezing and where the length of the dry-type sprinkler has the minimum exposure length depicted in Figure 10. Refer to the Exposure Length section.

For wet pipe system installations of 1 inch NPT Series DS-2 Dry-Type Sprinklers connected to CPVC piping, use only the following TYCO CPVC fittings:

- 1" x 1" NPT Female Adapter (P/N 80145)
- 1" x 1" x 1" NPT Sprinkler Head Adapter Tee (P/N 80249)

For dry pipe system installations, use only the side outlet of maximum 2-1/2-inch reducing tee when locating Series DS-2 Dry-Type Sprinklers directly below the branchline. Otherwise, use the configuration shown in Figure 9 to assure complete water drainage from above Series DS-2 Dry-Type Sprinklers and the branchline. Failure to do so may result in pipe freezing and water damage.

| Ambient Temperature Exposed to Discharge End of Sprinkler | Temperatures for Heated Area ¹ | | |
|---|--|-------------|-------------|
| | 40°F (4°C) | 50°F (10°C) | 60°F (16°C) |
| | Minimum Exposed Barrel Length ² , Inches (mm) | | |
| 40°F (4°C) | 0 | 0 | 0 |
| 30°F (-1°C) | 0 | 0 | 0 |
| 20°F (-7°C) | 4 (100) | 0 | 0 |
| 10°F (-12°C) | 8 (200) | 1 (25) | 0 |
| 0°F (-18°C) | 12 (305) | 3 (75) | 0 |
| -10°F (-23°C) | 14 (355) | 4 (100) | 1 (25) |
| -20°F (-29°C) | 14 (355) | 6 (150) | 3 (75) |
| -30°F (-34°C) | 16 (405) | 8 (200) | 4 (100) |
| -40°F (-40°C) | 18 (455) | 8 (200) | 4 (100) |
| -50°F (-46°C) | 20 (510) | 10 (255) | 6 (150) |
| -60°F (-51°C) | 20 (510) | 10 (255) | 6 (150) |

Notes:

1. For protected area temperatures that occur between values listed above, use the next cooler temperature.
2. These lengths are inclusive of wind velocities up to 30 mph (18,6 kph).

TABLE B
EXPOSED SPRINKLER BARRELS IN WET PIPE SYSTEMS
MINIMUM RECOMMENDED LENGTHS

Clearance Space

In accordance with Section 8.4.9.2 of the 2010 edition of NFPA 13, when connecting an area subject to freezing and an area containing a wet pipe sprinkler system, the clearance space around the sprinkler barrel of dry-type sprinklers must be sealed. Due to temperature differences between two areas, the potential for the formation of condensation in the sprinkler and subsequent ice build-up is increased. If this condensation is not controlled, ice build-up can occur that might damage the dry-type sprinkler and/or prevent proper operation in a fire situation.

Use of the Model DSB-2 Dry Sprinkler Boot, described in Technical Data Sheet TFP591 and shown in Figure 11, can provide the recommended seal.

NOTICE

Do not install Series DS-2 Dry-Type Sprinkler into any other type fitting without first consulting the Technical Services department. Failure to use the appropriate fitting may result in one of the following:

- failure of the sprinkler to operate properly due to formation of ice over the Inlet Plug or binding of the Inlet Plug
- insufficient engagement of the Inlet pipe-threads with consequent leakage

Drainage

In accordance with the minimum requirements of the National Fire Protection Association for dry pipe sprinkler systems, branch, cross, and feed-main piping connected to dry sprinklers and subject to freezing temperatures must be pitched for proper drainage.

Exposure Length

When using dry sprinklers in wet pipe sprinkler systems to protect areas subject to freezing temperatures, use Table B to determine a sprinkler's appropriate exposed barrel length to prevent water from freezing in the connecting pipes due to conduction. The exposed barrel length measurement must be taken from the face of the sprinkler fitting to the surface of the structure or insulation that is exposed to the heated area. Refer to Figure 10 for an example.

For protected area temperatures between those given above, the minimum recommended length from the face of the fitting to the outside of the protected area may be determined by interpolating between the indicated values.

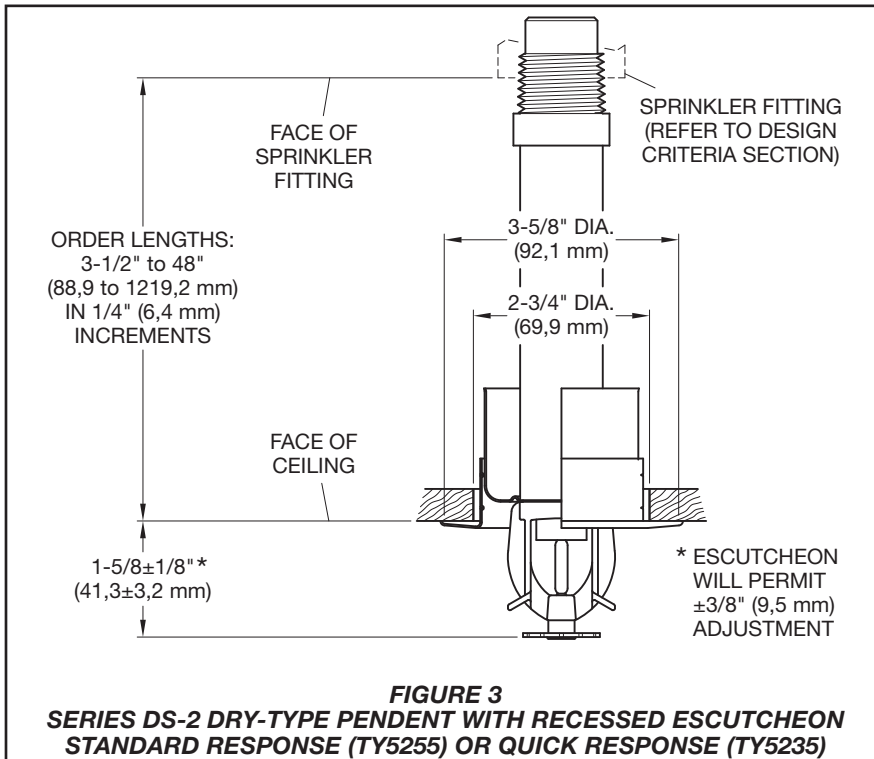
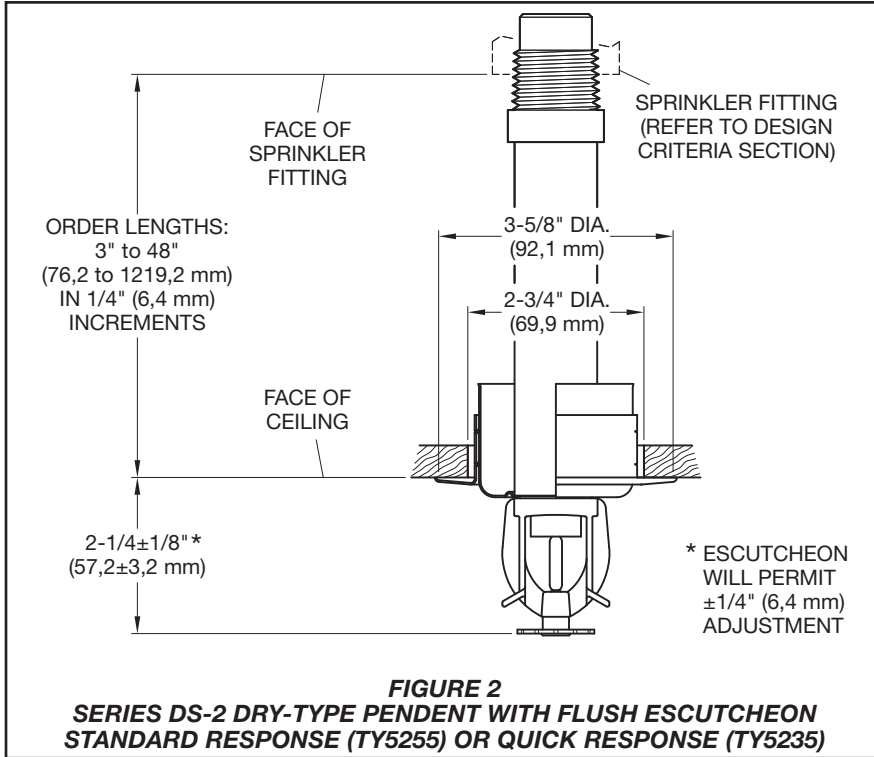

| K-factor LENGTH, Inches (mm) | K-factor, gpm/psi^{1/2} (lpm/bar^{1/2}) |
|---------------------------------------|--|
| 2-1/2 to 6-1/4 (63 mm to 159 mm) | 11.2 (161,3) |
| 6-1/2 to 10-1/2 (165 mm to 267 mm) | 11.1 (159,8) |
| 10-3/4 to 14-3/4 (273 mm to 375 mm) | 11.0 (158,4) |
| 15 to 18-3/4 (381 mm to 476 mm) | 10.9 (157,0) |
| 19 to 23 (483 mm to 584 mm) | 10.8 (155,5) |
| 23-1/4 to 26-3/4 (591 mm to 679 mm) | 10.7 (154,1) |
| 27-1/4 to 31-1/4 (692 mm to 794 mm) | 10.6 (152,6) |
| 31-1/2 to 35-1/4 (800 mm to 895 mm) | 10.5 (151,2) |
| 35-1/2 to 39-1/2 (902 mm to 1003 mm) | 10.4 (149,8) |
| 39-3/4 to 43-1/2 (1010 mm to 1105 mm) | 10.3 (148,3) |
| 43-3/4 to 48 (1111 mm to 1219 mm) | 10.2 (146,9) |

Notes:
K-factor Length is determined as follows:

- **Flush:** Order Length from Figure 2 plus 1/2 inch (12,7 mm)
- **Recessed:** Order Length from Figure 3 plus 1/4 inch (6,3 mm)
- **Extended:** Order Length from Figure 4 plus 3-1/4 inch (82,6 mm)
- **Without Escutcheon:** Order Length from Figure 5 minus 2-1/4 inches (57,2 mm)

TABLE C
DISCHARGE COEFFICIENTS

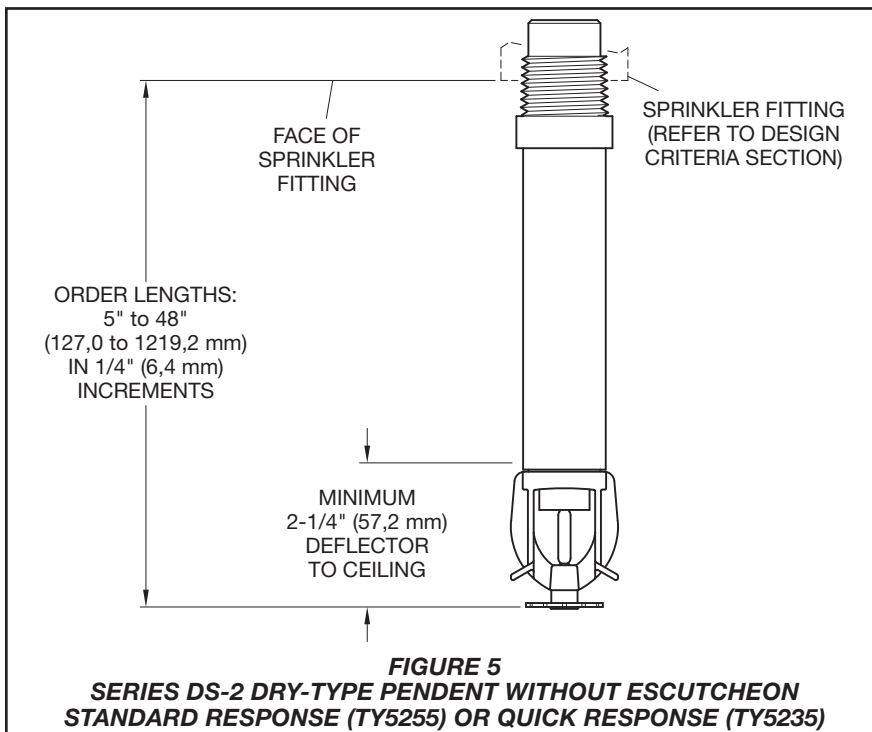
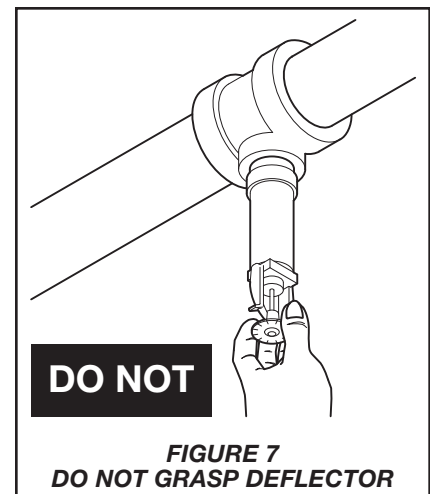
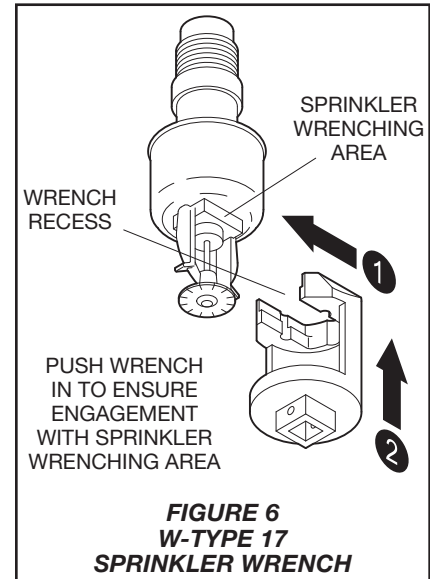
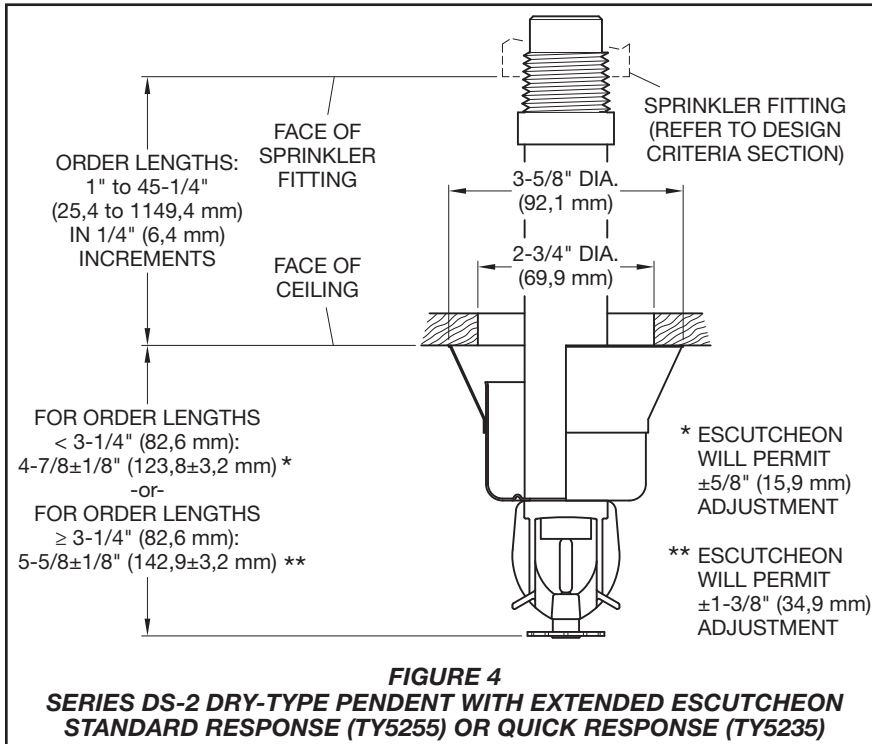

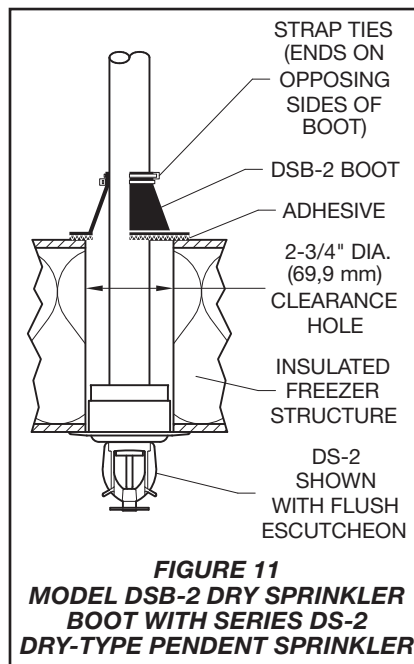
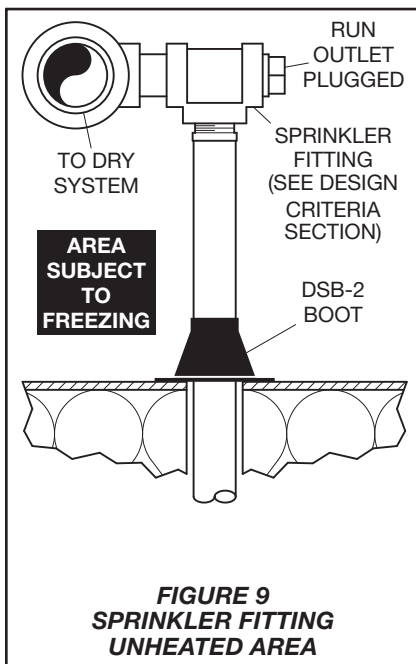
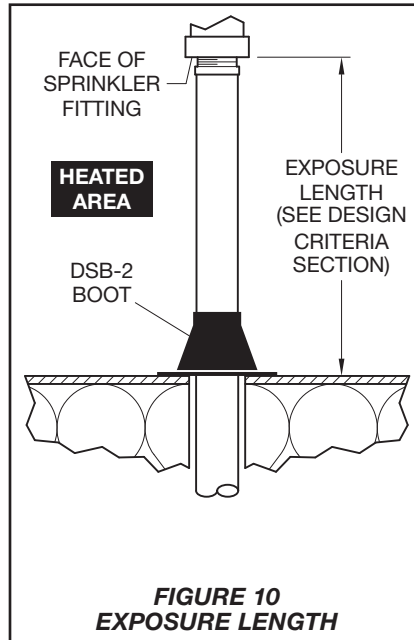
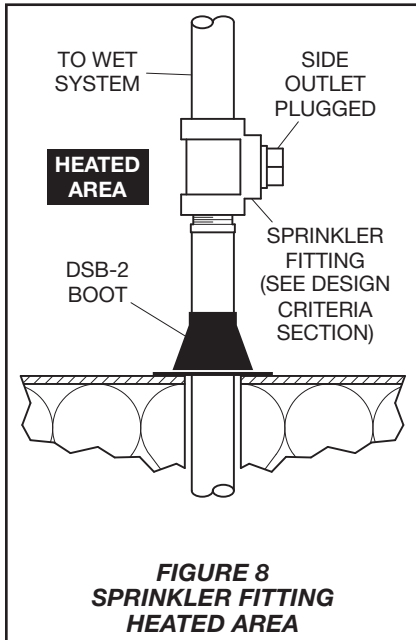

Installation

TYCO Series DS-2 Dry-Type Sprinklers, 11.2K Pendent, Standard (5 mm bulb) and Quick Response (3 mm bulb), and Standard Coverage must be installed in accordance with this section.

General Instructions

Series DS-2 Dry-Type Sprinklers must only be installed in fittings that meet the requirements of the Design Criteria section. Refer to the Design Criteria section for other important requirements regarding piping design and sealing of the clearance space around

the sprinkler Casing. With reference to Figure 7, do not grasp the sprinkler by the Deflector. Failure to follow this instruction may impair performance of the device.

Do not install any bulb-type sprinkler if the bulb is cracked or there is a loss of liquid from the bulb. With the sprinkler held horizontally, a small air bubble should be present. The diameter of the air bubble is approximately 1/16 inch (1,6 mm) for the 135°F (57°C) rating to 1/8 inch (3,2 mm) for the 360°F (182°C) rating.

A leak-tight 1 inch NPT sprinkler joint should be obtained by applying a minimum-to-maximum torque of 20 to 30 ft.-lbs. (26,8 to 40,2 Nm). Higher levels of torque may distort the sprinkler Inlet with consequent leakage or impairment of the sprinkler.

Do not attempt to compensate for insufficient adjustment in an Escutcheon Plate by under or over-tightening the sprinkler. Re-adjust the position of the sprinkler fitting to suit.

Note: Install pendent sprinklers only in the pendent position. The Deflector of a pendent sprinkler must be parallel to the ceiling.

Step 1. With a non-hardening pipe-thread sealant such as TEFLON applied to the Inlet threads, hand-tighten the sprinkler into the sprinkler fitting. Do not grasp the sprinkler by the Deflector (Ref. Figure 7).

Step 2. Wrench-tighten the sprinkler using either:

- a pipe wrench on the Inlet Band or the Casing (Ref. Figure 1)
- the W-Type 17 Sprinkler Wrench on the Wrench Flat (Ref. Figure 2)

Apply the Wrench Recess of the W-Type 17 Sprinkler Wrench to the Wrench Flat.

Note: If sprinkler removal becomes necessary, remove the sprinkler using the same wrenching method noted above. Sprinkler removal is easier when a non-hardening sealant was used and torque guidelines were followed. After removal, inspect the sprinkler for damage.

Step 3. After installing the ceiling and applying a ceiling finish, slide on the outer piece of the escutcheon until it comes in contact with the ceiling. Do not lift the ceiling panel out of its normal position.

When using the Deep Escutcheon, hold the outer piece in contact with the mounting surface (ceiling or wall). Then rotate the inner piece approximately 1/4 turn with respect to the outer piece, to hold the Deep Escutcheon firmly together.

Care and Maintenance

TYCO Series DS-2 Dry-Type Sprinklers, 11.2K Pendent, Standard (5 mm bulb) and Quick Response (3 mm bulb), and Standard Coverage must be maintained and serviced in accordance with this section.

Before closing a fire protection system main control valve for maintenance work on the fire protection system that it controls, obtain permission to shut down the affected fire protection systems from the proper authorities and notify all personnel who may be affected by this action.

Absence of the outer piece of an escutcheon, which is used to cover a clearance hole, may delay the time to sprinkler operation in a fire situation.

A Vent Hole is provided in the Bulb Seat (Figure 1) to indicate if the Dry Sprinkler is remaining dry. Evidence of leakage from the Vent Hole indicates potential leakage past the Inlet seal and the need to remove the sprinkler to determine the cause of leakage (e.g., an improper installation or an ice plug). Close the fire protection system control valve and drain the system before removing the sprinkler.

Sprinklers which are found to be leaking or exhibiting visible signs of corrosion must be replaced.

Automatic sprinklers must never be painted, plated, coated, or otherwise altered after leaving the factory. Modified sprinklers must be replaced. Sprinklers that have been exposed to corrosive products of combustion, but have not operated, should be replaced if they cannot be completely cleaned by wiping the sprinkler with a cloth or by brushing it with a soft bristle brush.

Care must be exercised to avoid damage to the sprinklers – before, during, and after installation. Sprinklers damaged by dropping, striking, wrench twist/slippage, or the like, must be replaced. Also, replace any sprinkler that has a cracked bulb or that has lost liquid from its bulb. (Refer to Installation Section.)

The owner is responsible for the inspection, testing, and maintenance of their fire protection system and devices in compliance with this document, as well as with the applicable standards of the National Fire Protection Association (e.g., NFPA 25), in addition to the standards of any other authorities having jurisdiction. Contact the installing contractor or product manufacturer with any questions.

Automatic sprinkler systems are recommended to be inspected, tested, and maintained by a qualified Inspection Service in accordance with local requirements and/or national codes.

Limited Warranty

For warranty terms and conditions, visit www.tyco-fire.com.

Ordering Procedure

Contact your local distributor for availability. When placing an order, indicate the full product name and part number (P/N).

Dry-Type Sprinkler

When ordering Series DS-2 Dry-Type Sprinklers, 11.2K Pendent, Standard (5 mm bulb) and Quick Response (3 mm bulb), and Standard Coverage, specify the following information:

- **SIN:**
 - TY5255 – Standard Response
 - TY5235 – Quick Response
- **Order Length:**

Dry-Type Sprinklers are furnished based upon Order Length as measured from the face of the ceiling to the face of the sprinkler fitting (Ref. Figures 2 through 5). After the measurement is taken, round it to the nearest 1/4 inch increment.
- **Inlet Connections:**
 - 1 Inch NPT (Standard)
 - ISO 7-R 1 (For information on ISO Inlet Thread Connections, contact your Tyco Sales Representative.)
- **Temperature Rating**
- **Sprinkler Finish**
- **Escutcheon Type and Finish, as applicable**
- **Part Number from Table D**

Sprinkler Wrench

Specify W-Type 17 Sprinkler Wrench, P/N 56-010-4-118

Sprinkler Boot

Specify Model DSB-2 Dry Sprinkler Boot, P/N 63-000-0-002

This Part Number includes one (1) Boot, two (2) Strap Ties, and 1/3 oz. of Adhesive (a quantity sufficient for installing one boot).

P/N* 61 - XXX - X - XXX

| | | | ORDER LENGTH ² | |
|----|--|-------------------|---------------------------|---------------|
| | | SIN | | |
| 10 | Standard Response Pendent with Flush Escutcheon | TY5255 (Figure 2) | 055 | 5.50" |
| 11 | Standard Response Pendent with Recessed Escutcheon | TY5255 (Figure 3) | 082 | 8.25" |
| 12 | Standard Response Pendent with Extended Escutcheon | TY5255 (Figure 4) | 180 | 18.00" |
| 13 | Standard Response Pendent without Escutcheon | TY5255 (Figure 5) | 187 | 18.75" |
| | | | 372 | 37.25" |
| | | | 480 | 48.00" |
| | | | TEMPERATURE RATING | |
| | | | 0 | 135°F (57°C) |
| | | | 1 | 155°F (68°C) |
| | | | 2 | 175°F (79°C) |
| | | | 3 | 200°F (93°C) |
| | | | 4 | 286°F (141°C) |

| | | SPRINKLER FINISH | ESCUTCHEON FINISH ¹ |
|---|------------------------|------------------------|--------------------------------|
| 0 | CHROME PLATED | SIGNAL WHITE (RAL9003) | |
| 1 | NATURAL BRASS | SIGNAL WHITE (RAL9003) | |
| 4 | SIGNAL WHITE (RAL9003) | SIGNAL WHITE (RAL9003) | |
| 5 | NATURAL BRASS | BRASS PLATED | |
| 9 | CHROME PLATED | CHROME PLATED | |

| | | SIN |
|----|---|-------------------|
| 30 | Quick Response Pendent with Flush Escutcheon | TY5235 (Figure 2) |
| 31 | Quick Response Pendent with Recessed Escutcheon | TY5235 (Figure 3) |
| 32 | Quick Response Pendent with Extended Escutcheon | TY5235 (Figure 4) |
| 35 | Quick Response Pendent without Escutcheon | TY5235 (Figure 5) |

- Notes:**
- Escutcheon Finish applies to sprinklers with escutcheons.
 - Dry-Type Sprinklers are furnished based upon "Order Length" as measured per Figures 2 through 5, as applicable, and for each individual sprinkler where it is to be installed. After the measurement is taken, round it to the nearest 1/4 inch increment.
- * Use Prefix "I" for ISO 7-R1 Connection (e.g., I-61-101-1-180).

TABLE D
SERIES DS-2 STANDARD AND QUICK RESPONSE, STANDARD COVERAGE, DRY-TYPE SPRINKLERS
PART NUMBER SELECTION