



Series DS-C Dry Type Sprinklers 5.6K Concealed Pendent Standard and Quick Response, Standard Coverage

General Description

TYCO Series DS-C Dry Type Sprinklers, 5.6K Concealed Pendent, Standard (5 mm Bulb) and Quick Response (3 mm Bulb) and Standard Coverage, are decorative sprinklers featuring a flat cover plate designed to conceal the sprinkler. This type of sprinkler is typically used to provide a sprinkler drop from an unheated attic into an area where aesthetics is a concern, such as nursing homes, restaurants, and schools.

Each unit includes a Cover Plate Assembly that conceals the sprinkler operating components above the ceiling. The separable two-piece design of the Cover Plate and Support Cup Assemblies allows installation of the sprinklers and pressure testing of the fire protection system prior to installation of a suspended ceiling or application of the finish coating to a fixed ceiling. They also permit removal of suspended ceiling panels for access to building service equipment without having to first shut down the fire protection system and remove sprinklers. Also, the separable two-piece design of the Sprinkler provides for 1/2 inch (12,7 mm) of vertical adjustment.

Series DS-C Sprinklers are shipped with a Disposable Protective Cap. The Protective Cap is temporarily removed for installation, and then it can be replaced to help protect the sprinkler while the ceiling is installed or finished. The tip of the Protective Cap

can also be used to mark the center of the ceiling hole into plaster board and ceiling tiles by gently pushing the ceiling product against the Protective Cap. When the ceiling installation is complete the Protective Cap is removed and the Cover Plate Assembly installed.

NOTICE

Series DS-C Dry Type Concealed Pendent Sprinklers described herein must be installed and maintained in compliance with this document and the applicable standards of the National Fire Protection Association, in addition to the standards of any authorities having jurisdiction. Failure to do so may impair the performance of these devices.

The owner is responsible for maintaining their fire protection system and devices in proper operating condition. The installing contractor or sprinkler manufacturer should be contacted with any questions.

Series DS-C Dry Type Concealed Pendent Sprinklers must only be installed in fittings that meet the requirements of the Design Criteria section.

Sprinkler Identification Numbers (SINs)

TY3535 - 3 mm Bulb
TY3555 - 5 mm Bulb



Technical Data

Approvals

UL and C-UL Listed
NYC Approved under MEA 352-01-E-2

Maximum Working Pressure

175 psi (12,1 bar)

Inlet Thread Connections

- 1 inch NPT (Standard Order)
- ISO 7-R1

Discharge Coefficient

K=5.6 GPM/psi^{1/2} (80,6 LPM/bar^{1/2})

Temperature Ratings

- 155°F (68°C) Sprinkler with 139°F (59°C) Cover Plate
- 200°F (93°C) Sprinkler with 165°F (74°C) Cover Plate

Adjustment

1/2 inch (12,7 mm)

Finishes

Refer to Ordering Procedure section.

IMPORTANT

Always refer to Technical Data Sheet TFP700 for the "INSTALLER WARNING" that provides cautions with respect to handling and installation of sprinkler systems and components. Improper handling and installation can permanently damage a sprinkler system or its components and cause the sprinkler to fail to operate in a fire situation or cause it to operate prematurely.

Physical Characteristics

Inlet.....	Copper
Plug.....	Copper
Yoke.....	Stainless Steel
Casing.....	Galvanized Carbon Steel
Insert.....	Bronze
Bulb Seat.....	Stainless Steel
Bulb.....	Glass
Deflector.....	Bronze
Frame.....	Bronze
Guide Tube.....	Stainless Steel
Water Tube.....	Stainless Steel
Spring.....	Stainless Steel
Gasketed Spring Plate Seal.....	Beryllium Nickel w/TEFLON
Support Cup.....	Chrome Plated Steel
Guide Pins.....	Stainless Steel
Compression Screw.....	Brass
Cover Plate.....	Brass
Retainer.....	Brass
Ejection Spring.....	Stainless Steel

Operation

When TYCO Series DS-C Dry Type Concealed Pendent Sprinklers is in service, water is prevented from entering the assembly by the Plug with Gasketed Spring Plate Seal (Figure 1) in the Inlet of the Sprinkler.

When exposed to heat from a fire, the Cover Plate, which is normally soldered to the Retainer at three points, falls away to expose the Sprinkler Assembly. At this point the Deflector supported by the Guide Pins drops down to its operational position.

The glass bulb contains a fluid that expands when exposed to heat. When the rated temperature is reached, the fluid expands sufficiently to shatter the glass bulb, and the Bulb Seat is released.

The compressed Spring is then able to expand and push the Water Tube as well as the Guide Tube outward. This action simultaneously pulls inward on the Yoke, withdrawing the Plug with Gasketed Spring Plate Seal, from the Inlet, allowing the sprinkler to activate and flow water.

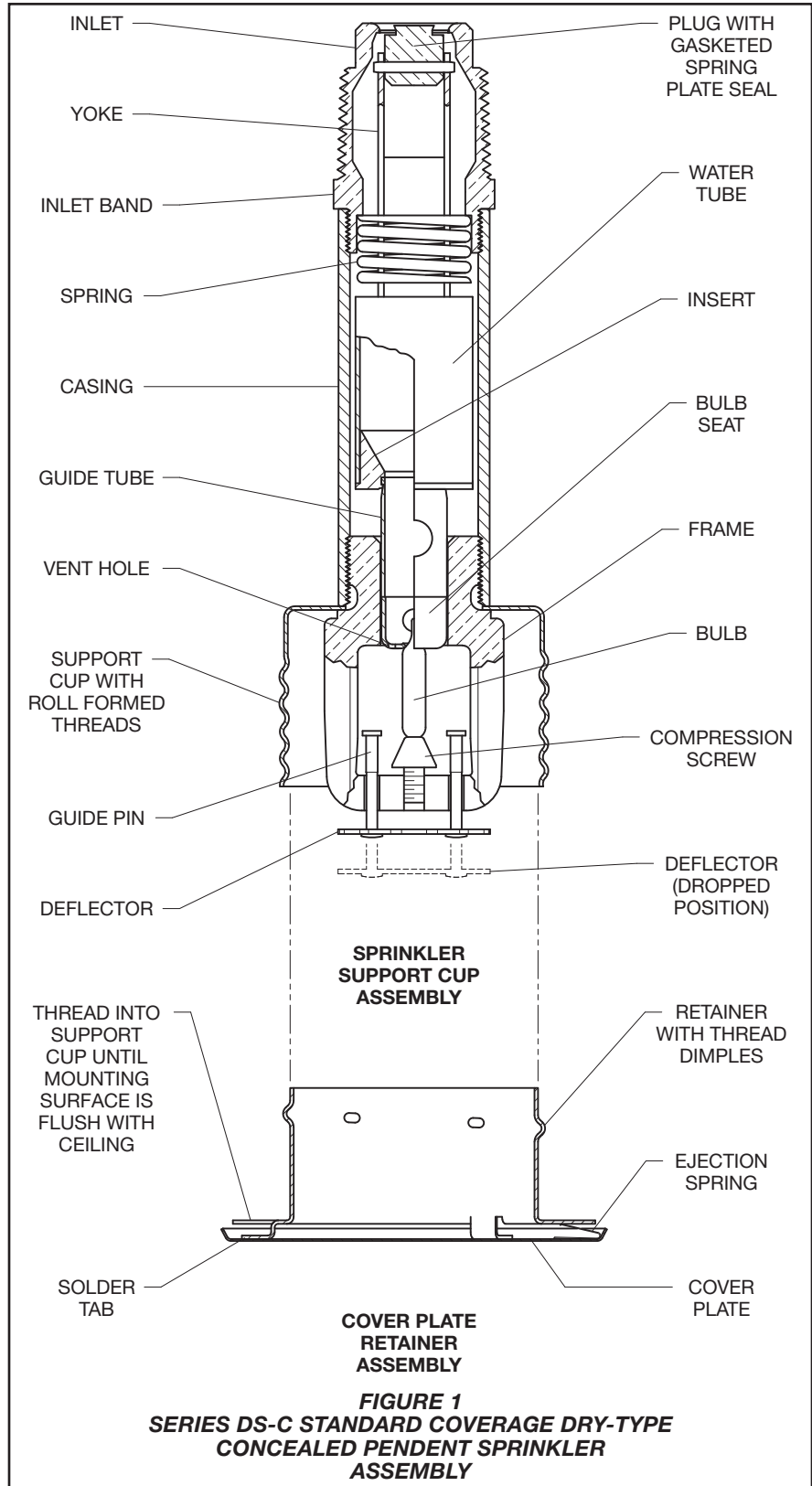

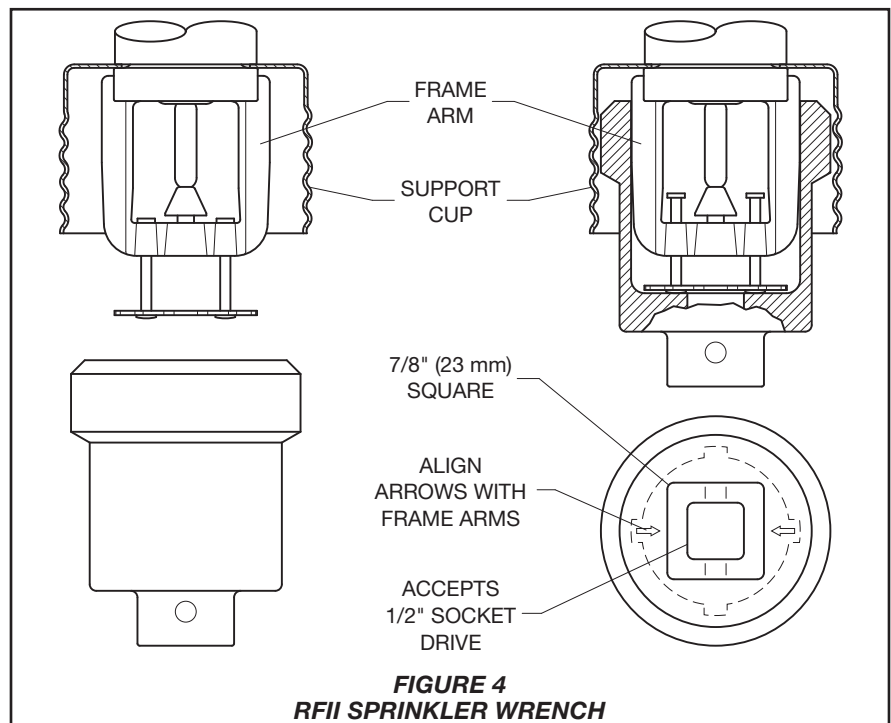
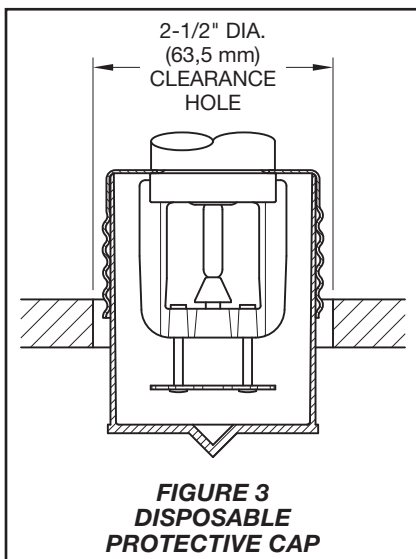
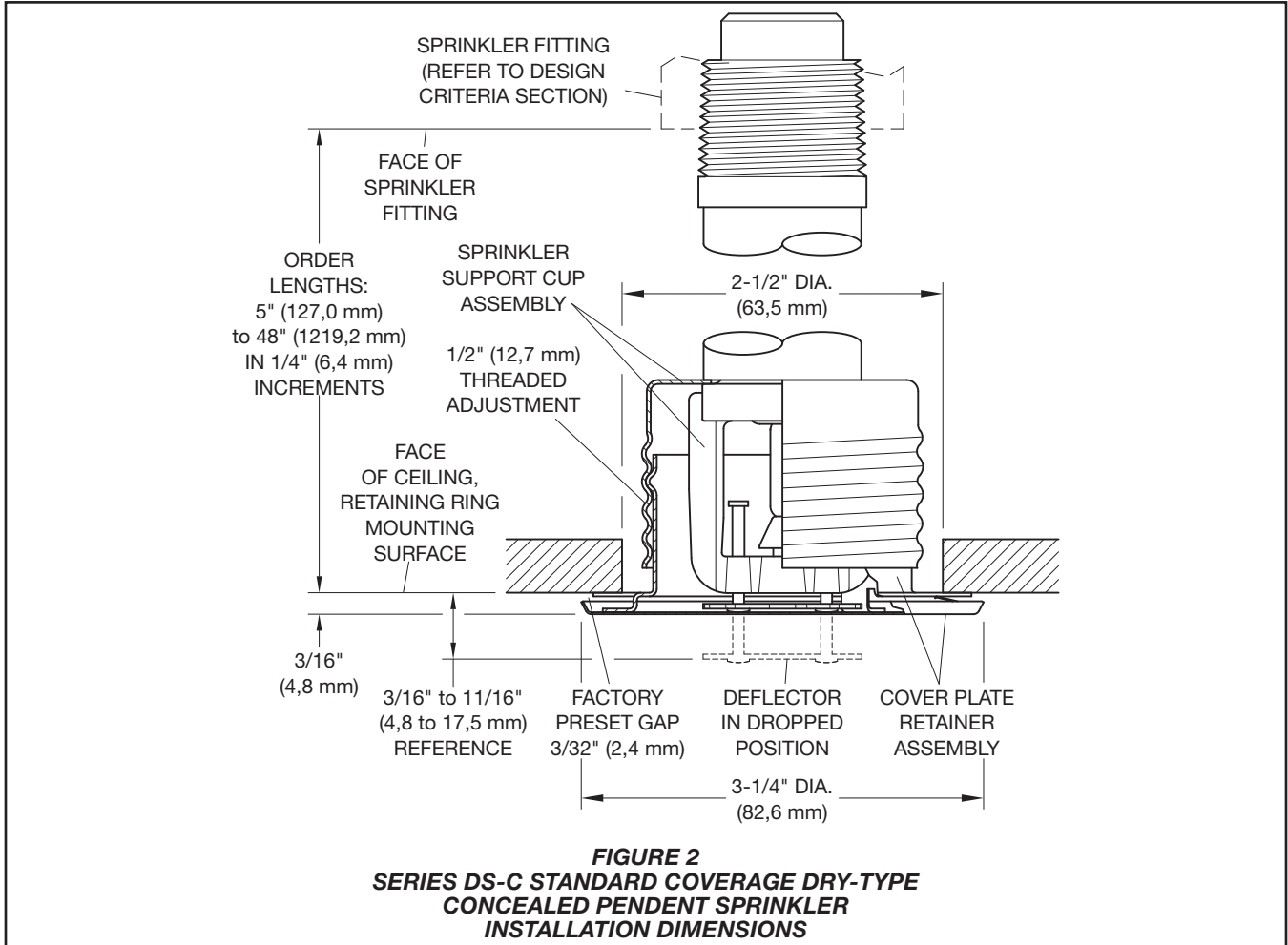

Design Criteria

TYCO Series DS-C 3 mm bulb-type Dry Type Concealed Pendent Sprinklers (TY3535) are UL and C-UL Listed as quick response, standard spray sprinklers for use in accordance with the current NFPA standard.

Series DS-C 5 mm bulb-type Dry Type Concealed Pendent Sprinklers (TY3555) are UL and C-UL Listed as standard response, standard spray sprinklers for use in accordance with the current NFPA standard.

Series DS-C Dry Type Sprinklers are only listed when installed with Series RFI Concealed Cover Plates having a factory-applied painted or metallic finish.

Series DS-C Dry Type Sprinklers must not be used in applications where the air pressure above the ceiling is greater than that below. Down drafts through the Support Cup could delay sprinkler operation in a fire situation.

Sprinkler Fittings

Install 1 inch NPT Series DS-C Dry Type Concealed Pendent Sprinklers in the 1 inch NPT outlet or run of the following fittings:

- malleable or ductile iron threaded tee fittings that meet the dimensional requirements of ANSI B16.3 (Class 150)
- cast iron threaded tee fittings that meet the dimensional requirements of ANSI B16.4 (Class 125)

Do not install Series DS-C Dry Type Concealed Pendent Sprinklers into elbow fittings. The Inlet of the sprinkler can contact the interior of the elbow.

The unused outlet of the threaded tee is plugged as shown in Figures 5 and 6.

You can also install Series DS-C Dry-Type Sprinklers in the outlet.

The configuration shown in Figure 5 is only applicable for wet pipe systems where the sprinkler fitting and water-filled pipe above the sprinkler fitting are not subject to freezing and where the length of the Dry Type Sprinkler has the minimum exposure length depicted in Figure 7. Refer to the Exposure Length section.

For wet pipe system installations of 1 inch NPT Series DS-C Dry Type Sprinklers connected to CPVC piping, use only the following TYCO CPVC fittings:

- 1" x 1" NPT Female Adapter (P/N 80145).
- 1" x 1" x 1" NPT Sprinkler Head Adapter Tee (P/N 80249).

For dry pipe system installations, use only the side outlet of maximum 2-1/2 inch reducing tee when locating Series DS-C Dry Type Sprinklers directly below the branch line. Otherwise, use the configuration shown in Figure 6 to assure complete water drainage from above Series DS-C Dry Type Sprinklers and the branch line. Failure to do so may result in pipe freezing and water damage.

NOTICE

Do not install Series DS-C Dry Type Sprinklers into any other type fitting without first consulting the Technical Services Department. Failure to use the appropriate fitting may result in one of the following:

- *failure of the sprinkler to operate properly due to formation of ice over the Inlet Plug or binding of the Inlet Plug*
- *insufficient engagement of the Inlet pipe-threads with consequent leakage*

Drainage

In accordance with the minimum requirements of the National Fire Protection Association for dry pipe sprinkler systems, branch, cross, and feed-main piping connected to Dry Sprinklers and subject to freezing temperatures must be pitched for proper drainage.

Exposure Length

When using Dry Type Sprinklers in wet pipe sprinkler systems to protect areas subject to freezing temperatures, use Table A to determine a sprinkler's appropriate exposed barrel length to prevent water from freezing in the connecting pipes due to conduction. The exposed barrel length measurement must be taken from the face of the sprinkler fitting to the surface of the structure or insulation that is exposed to the heated area. Refer to Figure 7 for an example.

For protected area temperatures between those given above, the minimum recommended length from the face of the fitting to the outside of the protected area may be determined by interpolating between the indicated values.

Do not attempt to add additional insulation around the barrel in the heated area as a method to minimize condensation. This will reduce the calculated "Exposure Length".

Clearance Space

In accordance with Section 8.4.9.2 of the 2010 edition of NFPA 13, where dry sprinklers are connected to wet pipe sprinkler systems protecting insulated freezer structures, the clearance space around the sprinkler barrel of Dry Type Sprinklers must be sealed. Due to temperature differences between two

areas, the potential for the formation of condensation in the sprinkler and subsequent ice build-up is increased. If this condensation is not controlled, ice build-up can occur that might damage the dry type sprinkler and/or prevent proper operation in a fire situation.

Use of the Model DSB-2 Dry Sprinkler Boot, described in technical data sheet TFP591 and shown in Figure 8, will provide the recommended seal.

NOTICE

For applications where a bore greater than 1-3/4 inches in diameter has been cut through the entire height of an insulated freezer ceiling creating a cavity above the sprinkler support cup (Figure 8), the cavity must not be filled.

Ambient Temperature Exposed to Discharge End of Sprinkler	Temperatures for Heated Area ^a		
	40°F (4°C)	50°F (10°C)	60°F (16°C)
	Minimum Exposed Barrel Length, Inches (mm) ^b		
40°F (4°C)	0	0	0
30°F (-1°C)	0	0	0
20°F (-7°C)	4 (100)	0	0
10°F (-12°C)	8 (200)	1 (25)	0
0°F (-18°C)	12 (305)	3 (75)	0
-10°F (-23°C)	14 (355)	4 (100)	1 (25)
-20°F (-29°C)	14 (355)	6 (150)	3 (75)
-30°F (-34°C)	16 (405)	8 (200)	4 (100)
-40°F (-40°C)	18 (455)	8 (200)	4 (100)
-50°F (-46°C)	20 (510)	10 (255)	6 (150)
-60°F (-51°C)	20 (510)	10 (255)	6 (150)

NOTES:
a. For protected area temperatures that occur between values listed above, use the next cooler temperature.
b. These lengths are inclusive of wind velocities up to 30 mph (18,6 kph).

TABLE A
EXPOSED SPRINKLER BARRELS IN WET PIPE SYSTEMS
MINIMUM RECOMMENDED LENGTHS

Installation

TYCO Series DS-C Dry Concealed Pendent Sprinklers must be installed in accordance with this section.

Series DS-C Dry Type Concealed Pendent Sprinklers must only be installed in fittings that meet the requirements of the Design Criteria section. Refer to the Design Criteria section for other important requirements regarding piping design and sealing of the clearance space around the Sprinkler Casing.

Do not install any bulb type sprinkler if the bulb is cracked or there is a loss of liquid from the bulb. With the sprinkler held horizontally, a small air bubble should be present. The diameter of the air bubble is approximately 1/16 inch (1,6 mm).

A leak-tight 1 inch NPT sprinkler joint should be obtained by applying a minimum-to-maximum torque of 20 to 30 ft. lbs. (26,8 to 40,2 Nm). Higher levels of torque may distort the sprinkler Inlet with consequent leakage or impairment of the sprinkler.

Do not attempt to compensate for insufficient adjustment in the Sprinkler Assembly by under or over-tightening the Sprinkler/Support Cup Assembly. Re-adjust the position of the sprinkler fitting to suit.

Step 1. Install the sprinkler in the pendent position with the centerline of the sprinkler perpendicular to the mounting surface.

Step 2. With a non-hardening pipe-thread sealant such as TEFLON pipe-thread sealant applied to the Inlet threads, hand-tighten the sprinkler into the sprinkler fitting.

Step 3. Wrench-tighten the sprinkler using either:

- a pipe wrench on the Inlet Band or the Casing (Figure 1).
- the RFII Sprinkler Wrench on the wrench flat (Figure 4).

Apply the wrench recess of the RFII Sprinkler Wrench to the wrench flat.

Note: If sprinkler removal becomes necessary, remove the sprinkler using the same wrenching method noted above. Sprinkler removal is easier when a non-hardening sealant was used and torque guidelines were followed. After removal, inspect the sprinkler for damage.

When using the RFII Sprinkler Wrench, temporarily remove the Protective Cap. Replace the Protective Cap (Figure 4) by pushing it upwards until it bottoms out against the Support Cup. The Protective Cap helps prevent damage to the Deflector and Arms during ceiling installation and/or during application of the finish coating of the

ceiling. It may also be used to locate the center of the clearance hole by gently pushing the ceiling material up against the center point of the Protective Cap.

As long as the Protective Cap remains in place, the system is considered to be "Out of Service".

Step 4. After installing the ceiling and applying a ceiling finish, with the 2-1/2 inch (63,5 mm) diameter hole and in preparation for installing the Cover Plate Assembly, remove and discard the Protective Cap, and verify that the Deflector moves up and down freely. If the Sprinkler has been damaged and the Deflector does not move up and down freely, replace the entire Sprinkler assembly. Do not attempt to modify or repair a damaged sprinkler.

Step 5. Screw on the Cover Plate/Retainer Assembly until the Retainer (Figure 2) contacts the ceiling. Do not continue to screw on the Cover Plate/Retainer Assembly such that it lifts a ceiling panel out of its normal position. If the Cover Plate/Retainer Assembly cannot be engaged with the Support Cup or the Cover Plate/Retainer Assembly cannot be engaged sufficiently to contact the ceiling, reposition the Sprinkler Fitting.

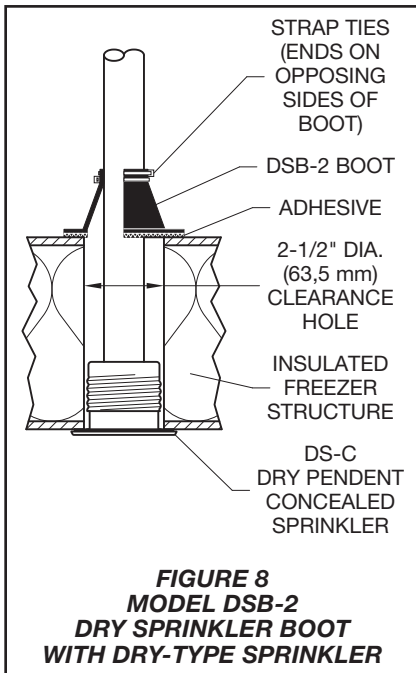
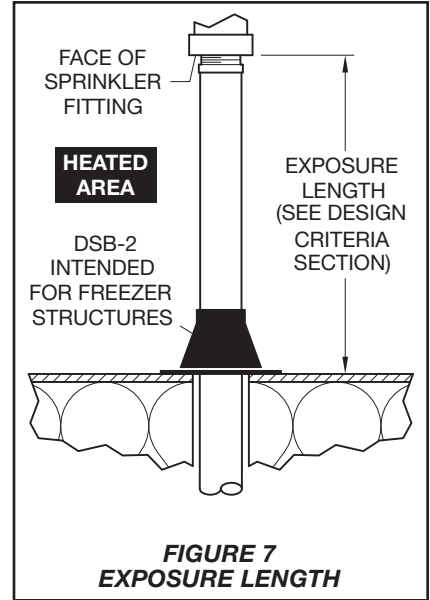
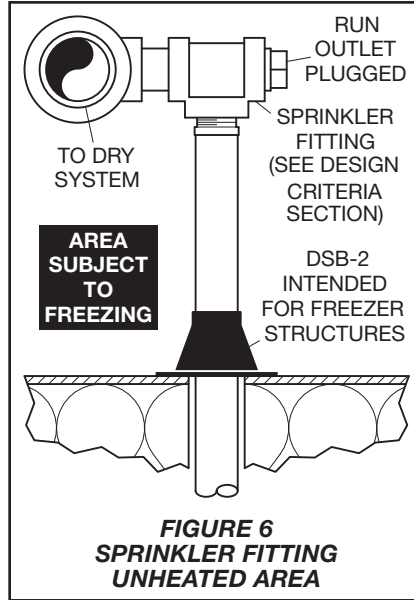
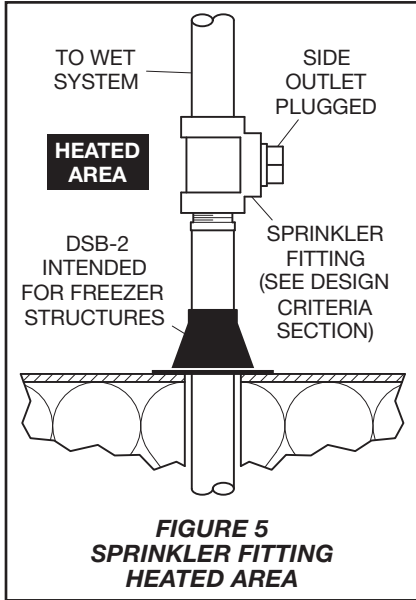

Absence of the Cover Plate Assembly may delay sprinkler operation in a fire situation.

A Vent Hole is provided in the Bulb Seat (Figure 1) to indicate if the Dry Sprinkler is remaining dry. Evidence of leakage from the Vent Hole indicate potential leakage past the Inlet seal and the need to remove the sprinkler to determine the cause of leakage; for example, an improper installation or an ice plug. Close the fire protection system control valve and the system drain before removing the sprinkler.

When properly installed, there is a nominal 3/16 inch (4,8 mm) air gap between the lip of the Cover Plate and the ceiling, as shown in Figure 2. This air gap is necessary for proper operation of the sprinkler. If the ceiling is to be repainted after the installation of the Sprinkler, care must be exercised to ensure that the new paint does NOT seal off any of the air gap.

Do not pull the Cover Plate relative to the Enclosure. Separation may result.

Sprinklers which are found to be leaking or exhibiting visible signs of corrosion must be replaced.

Automatic sprinklers must never be painted, plated, coated, or otherwise altered after leaving the factory. Modified sprinklers must be replaced. Sprinklers that have been exposed to corrosive products of combustion, but have not operated, should be replaced if they cannot be completely cleaned by wiping the sprinkler with a cloth or by brushing it with a soft bristle brush.

Care must be exercised to avoid damage to the sprinklers - before,

during, and after installation. Sprinklers damaged by dropping, striking, wrench twist/slippage, or the like, must be replaced. Also, replace any sprinkler that has a cracked bulb or that has lost liquid from its bulb. (Ref. Installation Section.)

If a sprinkler must be removed, do not reinstall it or a replacement without reinstalling the Cover Plate Assembly. If a Cover Plate Assembly becomes dislodged during service, replace it immediately.

The owner is responsible for the inspection, testing, and maintenance of their fire protection system and devices in compliance with this document, as well as with the applicable standards of the National Fire Protection Association (for example, NFPA 25), in addition to the standards of any other Authorities Having Jurisdiction. The installing contractor or sprinkler manufacturer should be contacted relative to any questions.

Automatic sprinkler systems are recommended to be inspected, tested, and maintained by a qualified Inspection Service in accordance with local requirements and/or national codes.

Care and Maintenance

TYCO Series DS-C Dry Type Concealed Pendent Sprinklers must be maintained and serviced in accordance with this section.

Before closing a fire protection system main control valve for maintenance work on the fire protection system that it controls, obtain permission to shut down the affected fire protection systems from the proper authorities and notify all personnel who may be affected by this action.

P/N* 60 - XXX - 1 - XXX

		SIN	TEMPERATURE RATING		ORDER LENGTH**	
46	Quick Response (3 mm Bulb)	TY3535	1	155°F (68°C)	055	5.50"
86	Standard Response (5 mm Bulb)	TY3555	3	200°F (93°C)	082	8.25"
					180	18.00"
					187	18.75"
					372	37.25"
					480	48.00"

Note
* Use Prefix "I" for ISO 7-R1 Connection (for example, I-60-461-1-180).
** Dry-Type Sprinklers are furnished based upon "Order Length" as measured per Figure 2, for each individual sprinkler where it is to be installed. After the measurement is taken, round it to the nearest 1/4 inch increment.

TABLE B
SERIES DS-C STANDARD COVERAGE, DRY-TYPE
CONCEALED PENDENT SPRINKLERS WITH 1 INCH NPT CONNECTION
PART NUMBER SELECTION

Ordering Procedure

Contact your local distributor for availability. When placing an order, indicate the full product name, including description and Part Number (P/N).

Dry Type Sprinkler Assemblies

When ordering 5.6 K-Factor Series DS-C Standard Coverage Dry Type Concealed Pendent Sprinklers, specify the following information:

- SIN
Quick Response TY3535 or
Standard Response TY3555
- Temperature Rating
- Order Length
Dry Type Sprinklers are furnished based upon Order Length as measured from the face of the ceiling to the face of the sprinkler fitting (Figure 2). After the measurement is taken, round it to the nearest 1/4 inch increment.
- Inlet Thread Connection
1 inch NPT or ISO 7-R1
- Part Number from Table B.

Separately Ordered Cover Plate

Specify: Series RFII Concealed Cover Plate with (temperature), (finish), and P/N (below).

139°F (59°C) Cover Plate for use with 155°F (68°C) Sprinkler

Grey White (RAL9002) P/N 56-792-0-135
Brass P/N 56-792-1-135
Pure White* (RAL9010) P/N 56-792-3-135
Signal White (RAL9003) P/N 56-792-4-135
Jet Black (RAL9005) P/N 56-792-6-135
Chrome P/N 56-792-9-135
Custom P/N 56-792-X-135

165°F (74°C) Cover Plate for use with 200°F (93°C) Sprinkler

Grey White (RAL9002) P/N 56-792-0-165
Brass P/N 56-792-1-165
Pure White* (RAL9010) P/N 56-792-3-165
Signal White (RAL9003) P/N 56-792-4-165
Jet Black (RAL9005) P/N 56-792-6-165
Chrome P/N 56-792-9-165
Custom P/N 56-792-X-165
* Eastern Hemisphere Sales Only

Sprinkler Wrench

Specify: RFII Sprinkler Wrench,
P/N 56-000-1-075.

Sprinkler Boot

Specify: Model DSB-2 Dry Sprinkler
Boot, P/N 63-000-0-002.

This Part Number includes one Boot, two Strap Ties, and 1/3 oz. of Adhesive (a sufficient quantity for installing one boot).