

Model CC3 — 4.2 and 5.6 K-factor Combustible Concealed Space Sprinklers Specific Application, Upright

General Description

The TYCO Model CC3 Combustible Concealed Sprinklers are quick response, upright, specific application sprinklers designed to provide protection of specific light hazard combustible, as well as non-combustible, concealed spaces requiring sprinkler protection. The Model CC3 Sprinklers comply with the criteria for the protection of combustible concealed spaces as described in NFPA 13.

The Model CC3 Sprinklers are designed for installation on BlazeMaster CPVC wet pipe systems and steel wet pipe or dry pipe sprinkler systems (refer to the respective Design Criteria sections). The Model CC3 Sprinklers are designed to be installed in the following arrangements for both wet CPVC and steel:

- 4.2K
 - 14 ft (4,3 m) maximum between sprinklers
 - 196 ft² (59,7 m²) maximum coverage area
- 5.6K
 - 16 ft (4,9 m) maximum between sprinklers
 - 256 ft² (78,0 m²) maximum coverage area
- 6 inch (152,4 mm) minimum height for joist with steel pipe or CPVC when insulation filled. 12 inch (305 mm) minimum height for all other arrangements and sizes

- 60 inch (1524 mm) maximum height from joist to joist and 84 inch (2134 mm) from floor to ceiling
- 60 inch (1524 mm) maximum height for truss and bar joist.

NOTICE

The Model CC3 Combustible Concealed Sprinklers described herein must be installed and maintained in compliance with this document, as well as with the applicable standards of the National Fire Protection Association, in addition to the standards of any other authorities having jurisdiction. Failure to do so may impair the performance of these devices.

The owner is responsible for maintaining their fire protection system and devices in proper operating condition. Contact the installing contractor or product manufacturer with any questions.

Sprinkler Identification Number

TY2199 – Upright, 4.2K
TY3199 – Upright, 5.6K

Technical Data

Approvals

UL Listed.
(Listings and approvals only apply to the service conditions indicated in the Design Criteria sections.)

Maximum Working Pressure

175 psi (12,1 bar)

Pipe Thread Connection

1/2 inch NPT

Discharge Coefficient

K = 4.2 gpm/psi^{1/2} (60,5 lpm/bar^{1/2})
K = 5.6 gpm/psi^{1/2} (80,6 lpm/bar^{1/2})

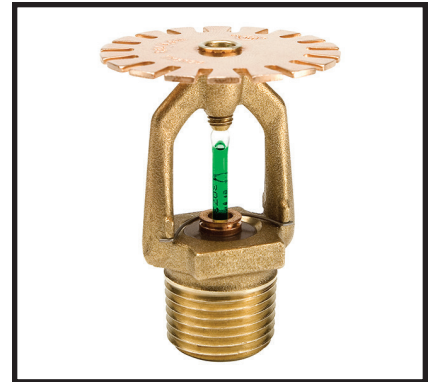

Temperature Rating

200°F (93°C)

Finish

Natural Brass

Physical Characteristics

Frame	Brass
Button	Bronze
Sealing Assembly	Beryllium Nickel w/TEFLON
Bulb	Glass (3 mm dia.)
Compression Screw	Brass
Deflector	Bronze

Operation

The glass bulb contains a fluid that expands when exposed to heat. When the rated temperature is reached, the fluid expands sufficiently to shatter the glass bulb allowing the sprinkler to activate and flow water.

IMPORTANT

Always refer to Technical Data Sheet TFP700 for the "INSTALLER WARNING" that provides cautions with respect to handling and installation of sprinkler systems and components. Improper handling and installation can permanently damage a sprinkler system or its components and cause the sprinkler to fail to operate in a fire situation or cause it to operate prematurely.

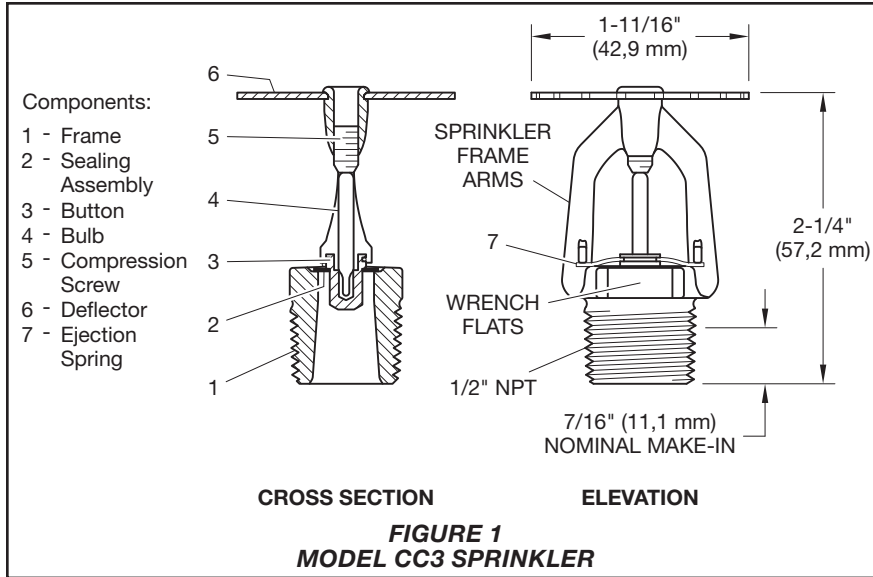

FIGURE 1
MODEL CC3 SPRINKLER

Design Criteria

Design criteria is provided as follows:

- 200°F (93°C), Model CC3 Combustible Concealed Sprinklers with CPVC pipe and horizontal slope above sprinklers not exceeding 2:12 (Refer to Page 2).
- 200°F (93°C), Model CC3 Combustible Concealed Sprinklers with steel pipe and horizontal slope above sprinklers not exceeding 2:12 (Refer to Page 3).

CPVC Pipe

Area Of Use (CPVC Pipe)

Horizontal (slope not exceeding 2:12) combustible concealed spaces of:

- Unobstructed wood truss construction or unobstructed bar joist construction (Figure 2).
- Non-combustible, insulation-filled solid wood or composite wood joist construction (Figure 3).

NOTE: In order to be considered “non-combustible insulation-filled solid wood or composite wood joist construction,” the insulation (including insulation provided with a combustible vapor barrier), must completely fill the pockets between the joists to the bottom of the joists, and the insulation must be secured in place with metal wire netting. The metal wire netting is intended to hold the insulation in place should the insulation become wetted by the operation of the Model CC3 Sprinklers in the event of a fire.

Concealed Space Area (CPVC Pipe)

The area of the concealed space is not limited; however, for both Figure 2 and Figure 3, where CPVC pipe is being utilized, draft curtains or full height walls must be provided at 1000 ft² (93 m²) areas. This draft curtain shall be at least 1/3 the depth of the concealed space or 8 inches (200 mm), whichever is greater, and be constructed using a material that will not allow heat to escape through or above the draft curtain.

Concealed Space Size (CPVC Pipe)

The depth of the concealed space is 60 inches (1524 mm) maximum to 6 inches (152 mm) minimum.

System Type (CPVC Pipe)

Light hazard, wet pipe system

Maximum Distance Between Model CC3 Sprinklers (CPVC Pipe)

TY2199 4.2K.14 ft (4,3 m)
 TY3199 5.6K.16 ft (4,9 m)

Maximum Coverage Area (CPVC Pipe)

TY2199 4.2K.196 ft² (59,7 m²)
 TY3199 5.6K.256 ft² (78,0 m²)

Minimum Distance Between Model CC3 Sprinklers (CPVC Pipe)

Minimum sprinkler spacing is 7 ft (2,1 m)

NOTE: Minimum spacing does not apply to any additional sprinklers required for protection of CPVC pipe that is offset over an obstruction.

Deflector Position (CPVC Pipe)

- 1-1/2 to 4 inches (40 to 100 mm) below upper deck for wood truss construction or bar joist construction (Figure 2)
- 1-1/2 to 4 inches (40 to 100 mm) below solid wood or composite wood joists (Figure 3)

Minimum Distance Away From Trusses (CPVC Pipe)

4-1/2 inches (114 mm)

Remote Area (CPVC Pipe)

The remote area is 1000 ft² (93 m²)

NOTE: The remote area does not include any additional sprinklers required for protection of CPVC pipe that is offset over an obstruction.

Required Minimum Density (CPVC Pipe)

0.10 gpm/ft² (4,1 mm/min)

Minimum Operating Pressure (CPVC Pipe)

7 psi (0,48 bar)

Obstructions (CPVC Pipe)

See Figure 8 in this data sheet for obstructions rules.

Use of UL Listed BlazeMaster CPVC Pipe with Model CC3 Sprinklers

Only BlazeMaster CPVC product may be used in concealed spaces requiring automatic sprinklers, when used in conjunction with Model CC3 Sprinklers. In order to use the BlazeMaster CPVC product for wood truss or bar joist construction, the horizontal run of pipe must be a maximum of 6 inches (150 mm) above the ceiling or noncombustible ceiling insulation, or 1/3 the depth of concealed space (as measured from the top surface of the ceiling to the bottom of the deck above), whichever is smaller (Figure 2). For insulation-filled solid wood or composite wood joist construction, the horizontal run of pipe must be a maximum of 6 inches (150 mm) above ceiling or non-combustible ceiling insulation, or 1/3 the depth of concealed space (as measured from the top surface of the ceiling to the bottom surface of the joist insulation above), whichever is smaller (Figure 3). The CPVC pipe can then be used to supply the Model CC3 Sprinklers, as well as the sprinklers below the ceiling. Unless modified by this technical data sheet, all other guidelines of the “BlazeMaster – Installation Instructions & Technical Manual” must be met. When using 1 inch (DN25) or larger pipe, a hanger must be located at the truss nearest a sprig for purposes of restraint. If using 3/4 inch (DN19) piping, all sprigs over 12 inches (305 mm) must be laterally braced using methods described in the NFPA standards.

Where the CPVC must be offset up and over an obstruction and the pipe exceeds the allowed horizontal positioning requirements specified above as well as shown in Figure 2 and 3, additional Model CC3 Sprinklers are to be installed as shown in Figure 2 and

3 to protect the BlazeMaster CPVC product.

A minimum lateral distance of 18 inches (460 mm) must be maintained between the CPVC pipe and heat pumps, fan motors, and heat lamps.

Steel Pipe

Area Of Use (Steel Pipe)

Horizontal (slope not exceeding 2:12) combustible concealed spaces of:

- Unobstructed wood truss construction or unobstructed bar joist construction (Figure 4)
- Solid wood joist construction (Figure 5) where the upper deck and ceiling joists may have a maximum depth of 12 inches (300 mm) and typical on center joist spacing of minimum 16 inches (400 mm)
- Non-combustible insulation-filled solid wood joist or wood composite joist construction (Figure 6)
- Obstructed wood truss construction (Figure 7)

NOTE: In order to be considered “non-combustible insulation-filled solid wood joist or composite wood joist construction”, the insulation (including insulation provided with a combustible vapor barrier), must completely fill the pockets between the joists to the bottom of the joists, and the insulation must be secured in place with metal wire netting. The metal wire netting is intended to hold the insulation in place should the insulation become wetted by the operation of the Model CC3 Sprinklers in the event of a fire.

Concealed Space Area (Steel Pipe)

The area of the concealed space is not limited; however,

- For unobstructed wood truss construction or concealed spaces of non-combustible, unobstructed bar joist construction (Figure 4) draft curtains or full height walls must be provided at 1000 ft² (93 m²) areas. This draft curtain shall be at least 1/3 the depth of the concealed space or 8 inches (200 mm), whichever is greater, and be constructed using a material that will not allow heat to escape through or above the draft curtain.
- For solid wood joist construction (Figure 5) and obstructed wood truss construction (Figure 7):

Blocking must be provided in each upper deck and ceiling joist channel at a maximum 32 ft (9,75 m) intervals. This blocking shall be installed to the full depth of the joists and be installed so as to not allow heat to escape through or above the blocking. The blocking must be

constructed using a non-combustible material or the joist construction material.

Draft curtains must protrude below the joist a minimum of 6 inches (150 mm) or 1/3 the depth of the concealed space, whichever is greater, and run parallel with the joist spaced at 31 ft (9,4 m) width maximum to limit the area to a maximum of 1000 ft² (93 m²). The draft curtains are to be constructed using a material that will not allow heat to escape through or above the draft curtain.

- For non-combustible, insulation-filled solid wood joist or composite wood joist construction (Figure 6), the requirement for draft curtains and blocking does not apply.

Concealed Space Size (Steel Pipe)

The minimum and maximum concealed space depth is as follows:

For unobstructed wood truss construction or concealed spaces of unobstructed bar joist construction (Figure 4) the maximum depth of the concealed space is 60 inches (1524 mm) from bottom of upper deck to top of ceiling, and the minimum depth is 6 inches (152 mm) from the bottom of the upper chords to the top of the lower chords.

For solid wood joist construction (Figure 5) and solid wood or composite wood joist construction the maximum depth of the concealed space is 84 inches (2134 mm) from bottom of upper deck to top of ceiling, and the minimum depth is 6 inches (152 mm) from the bottom of the upper deck joists to the top of the ceiling joists. If joist construction is filled with noncombustible insulation the maximum height of the space is 72 inches (1829 mm) (Figure 6).

For obstructed wood truss construction (Figure 7), the maximum depth of the concealed space is 84 inches (2134 mm) from bottom of upper deck to top of ceiling, and the minimum depth is 6 inches (152 mm) from the bottom of the upper chord to the top of the lower chord.

System Type (Steel Pipe)

Light hazard, wet or dry pipe system

NOTES: Use of the 4.2K sprinklers in dry pipe systems is permitted by section 8.3.4.4 of NFPA 13 (2013 edition) where piping is corrosion resistant or internally galvanized.

Maximum Distance Between Model CC3 Sprinklers (Steel Pipe)

TY2199 4.2K.14 ft (4,3 m)
TY3199 5.6K.16 ft (4,9 m)

Maximum Coverage Area (Steel Pipe)

TY2199 4.2K. 196 ft² (59,7 m²)
TY3199 5.6K. 256 ft² (78,0 m²)

Minimum Distance Between Model CC3 Sprinklers (Steel Pipe)

Minimum sprinkler spacing is 7 ft (2,1 m)

Deflector Position (Steel Pipe)

1-1/2 to 4 inches (40 to 100 mm) below upper deck for wood truss construction or concealed spaces of non-combustible bar joist construction (Figure 4)

1-1/2 to 2 inches (40 to 50 mm) below solid wood joist (Figure 5) or top chord of a wood truss that has a depth greater than 4 inches (Figure 7)

1-1/2 to 4 inches (40 to 100 mm) below non-combustible insulation-filled solid wood joists or composite wood joists (Figure 6)

Remote Area (Steel Pipe)

The remote area for wood truss construction or bar joist construction (Figure 4), solid wood joist construction (Figure 5), or obstructed wood truss construction (Figure 7) is 1000 ft² (93 m²) for wet pipe systems or 1300 ft² (121 m²) for dry pipe systems.

The remote area for non-combustible insulation-filled solid wood joist or wood composite joist construction (Figure 6) without draft curtains is to be calculated per the requirements of NFPA 13.

Required Minimum Density (Steel Pipe)

0.10 gpm/ft² (4,1 mm/min)

Minimum Operating Pressure (Steel Pipe)

7 psi (0,48 bar)

Obstructions (Steel Pipe)

See Figure 8 in this data sheet for obstructions rules.

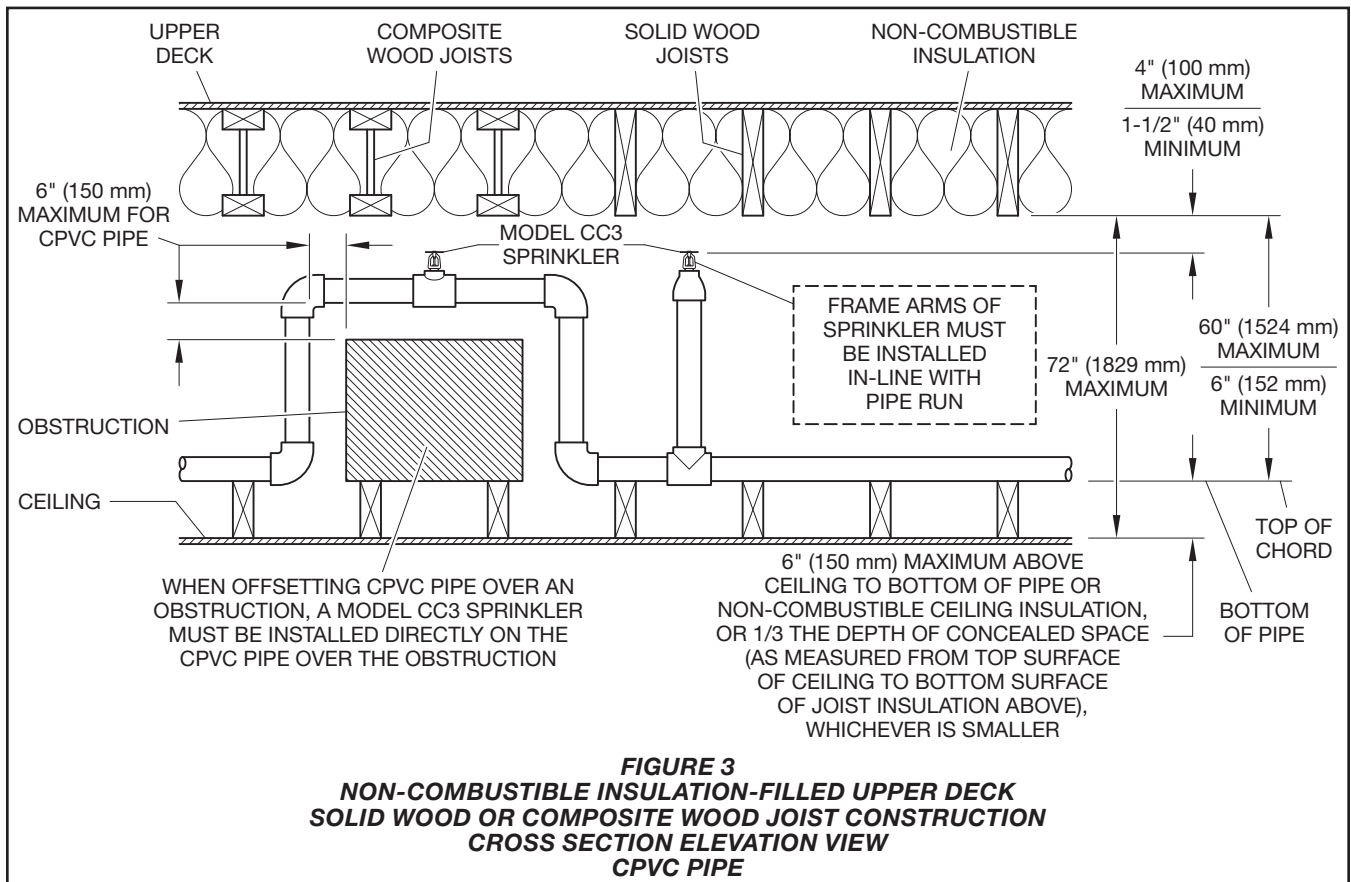
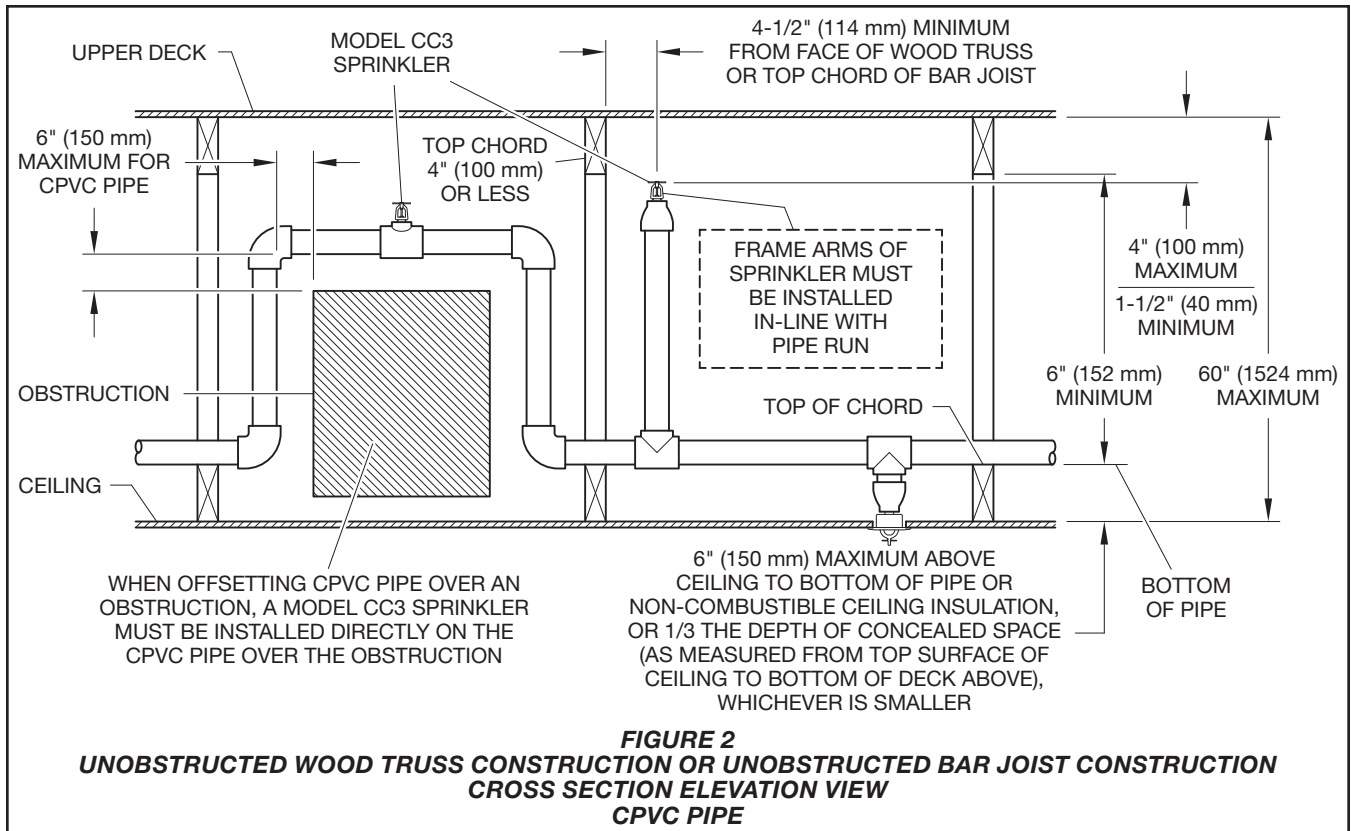

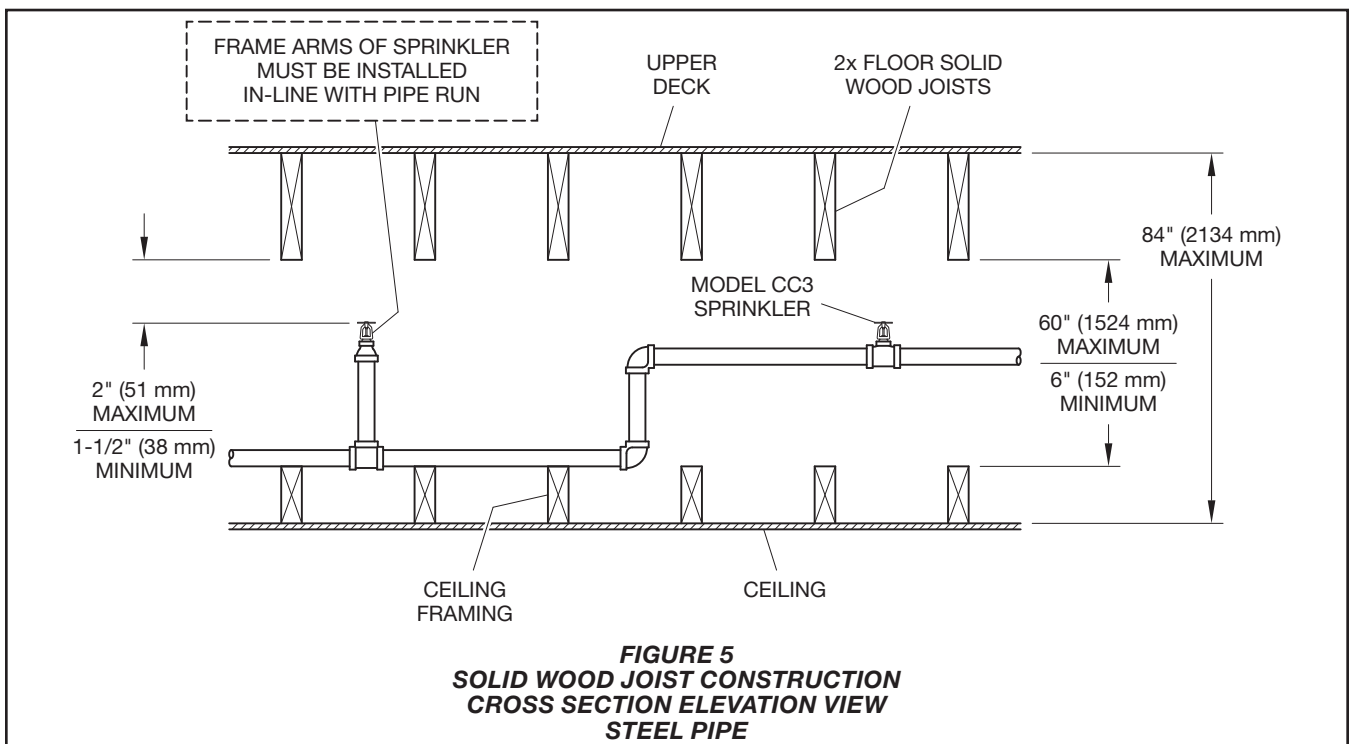
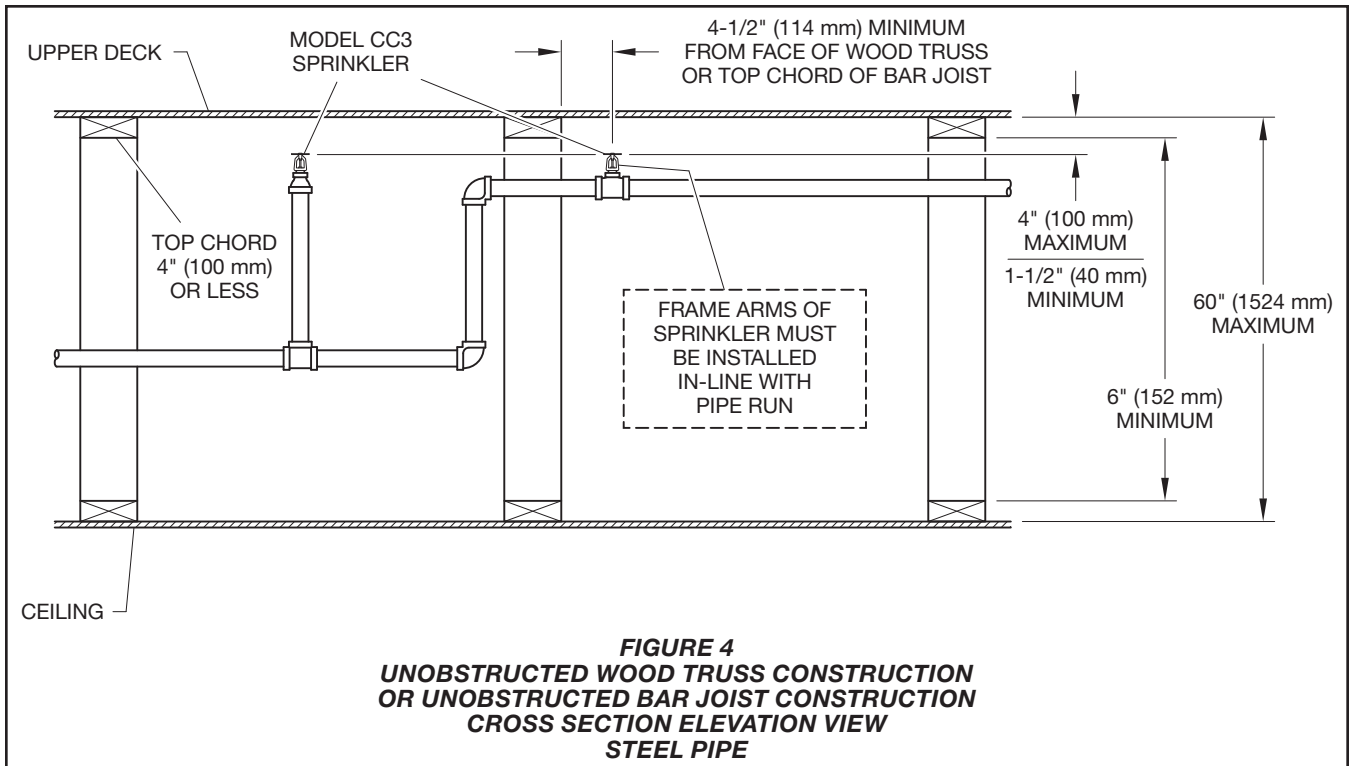

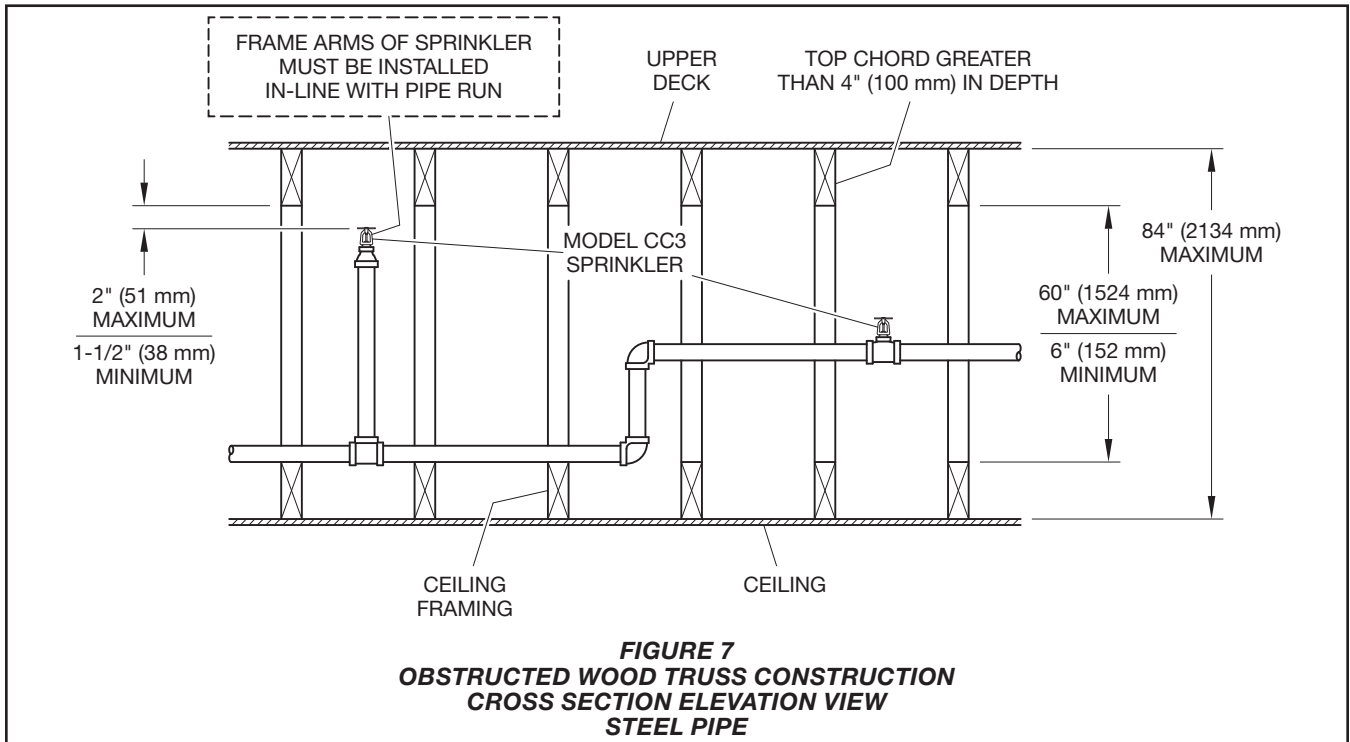
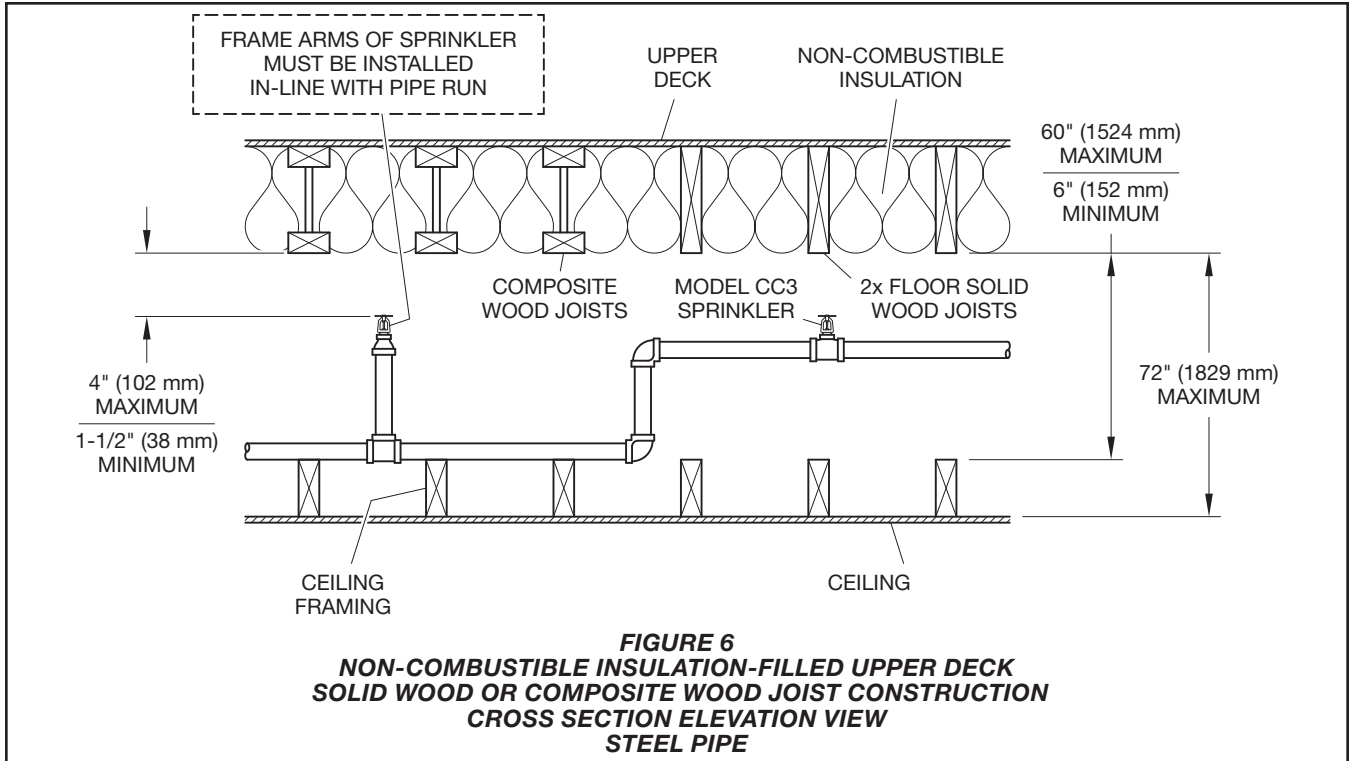

Installation

The Model CC3 Sprinklers must be installed in accordance with this section.

General Instructions

The Model CC3 Sprinklers are to be installed upright and with their frame arms in-line with the pipe run (reference Figures 1 - 8, as applicable).

Do not install any bulb type sprinkler if the bulb is cracked or there is a loss of liquid from the bulb. With the sprinkler held horizontally, a small air bubble should be present. The diameter of the air bubble is approximately 1/16 inch (1,6 mm) for the 200°F (93°C) temperature rating.

A leak-tight 1/2 inch NPT sprinkler joint should be obtained with a torque of 7 to 14 ft.-lbs. (9,5 to 19,0 Nm). Higher levels of torque may distort the sprinkler inlet with consequent leakage or impairment of the sprinkler.

The Model CC3 Sprinklers must only be installed in the upright position with the deflector parallel to the upper deck. With pipe thread sealant applied to the pipe threads, use only the W-Type 6 (End A) Sprinkler Wrench (Figure 9) for installation of the Model CC3 Sprinklers by applying the wrench to the sprinkler wrench flats only.

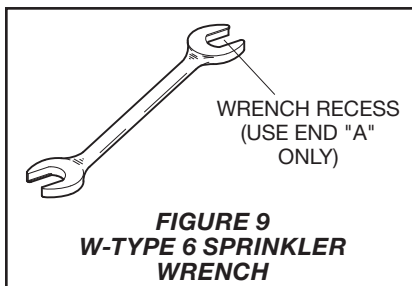
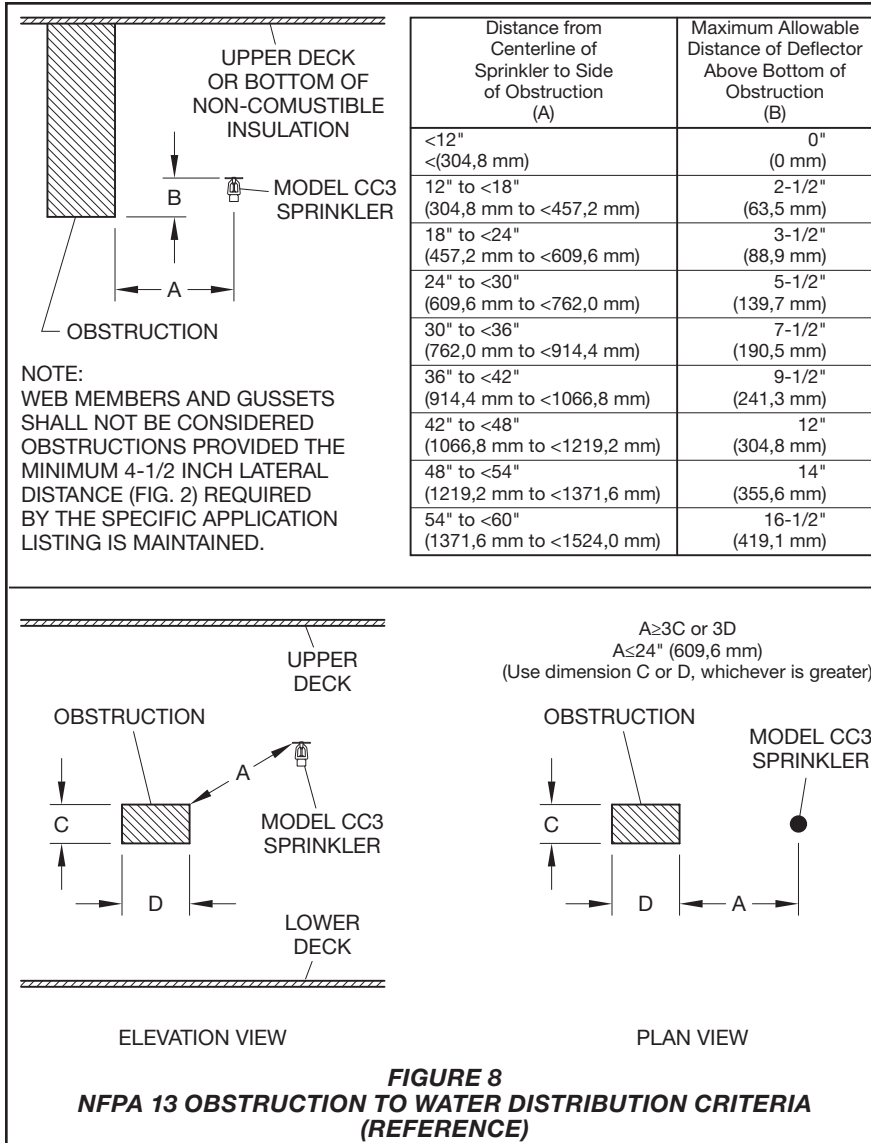

Care and Maintenance

The Model CC3 Sprinklers must be maintained and serviced in accordance with this section.

Before closing a fire protection system main control valve for maintenance work on the fire protection system that it controls, permission to shut down the affected fire protection systems must be obtained from the proper authorities and all personnel who may be affected by this action must be notified.

Sprinklers that are found to be leaking or exhibiting visible signs of corrosion must be replaced.

Automatic sprinklers must never be painted, plated, coated, or otherwise altered after leaving the factory. Modified sprinklers must be replaced. Sprinklers that have been exposed to corrosive products of combustion, but have not operated, should be replaced if they cannot be completely cleaned by wiping the sprinkler with a cloth or by brushing it with a soft bristle brush.

Care must be exercised to avoid damage to the sprinklers before, during, and after installation. Sprinklers damaged by dropping, striking, wrench twist/slippage, or the like, must be replaced. Also, replace any sprinkler that has a cracked bulb or that has lost liquid from its bulb. (Ref. Installation Section).

The owner is responsible for the inspection, testing, and maintenance of their fire protection system and devices in compliance with this document, as well as with the applicable standards of the National Fire Protection Association (e.g., NFPA 25), in addition to the standards of any other authorities having jurisdiction. Contact the installing contractor or sprinkler manufacturer with any questions.

It is recommended that automatic sprinkler systems be inspected, tested, and maintained by a qualified Inspection Service in accordance with local requirements and/or national codes.

Limited Warranty

For warranty terms and conditions, visit www.tyco-fire.com.

Ordering Procedure

Contact your local distributor for availability. When placing an order, indicate the full product name and Part Number (P/N).

Sprinkler Assemblies with NPT Thread Connections

Specify: SIN (specify), K-factor (specify), Model CC3, Combustible Concealed Space Sprinkler, Specific Application, Upright, 200°F (93°C), P/N (specify)

TY2199, 4.2K 51-311-1-200
TY3199, 5.6K 51-301-1-200

Sprinkler Wrench:

Specify: W-Type 6 Sprinkler Wrench, P/N 56-000-6-387