

Model CC2 — 4.2 and 5.6 K-factor Combustible Concealed Space Sprinklers™ Specific Application, Upright

General Description

The TYCO® Model CC2 Combustible Concealed Sprinklers are fast response, upright, specific application sprinklers designed to provide protection of specific light hazard combustible, as well as non-combustible, concealed spaces requiring sprinkler protection. The CC2 Sprinklers comply with the criterion for the protection of combustible concealed spaces as described in NFPA 13.

The Model CC2 Sprinklers are designed for installation on BlazeMaster® CPVC wet pipe systems and steel wet pipe or dry pipe sprinkler systems (refer to the respective Design Criteria sections). They provide the following features as compared to the 2.8K-factor Model CC1 Sprinklers described on Technical Data Sheet TFP630:

- Can be used on steel dry pipe sprinkler systems.
- Increased spacing from 10 ft. (3,1 m) to 12 ft. (3,7 m).
- Increased coverage area from 100 ft² (9,3 m²) to 144 ft² (13,4 m²).

The effectiveness of the Model CC2 Sprinklers in combustible concealed spaces was clearly evident during the full scale fire testing for this product.

Concealed spaces between floors, as well as low pitch attics (slope of 2:12 or less) are inherently shallow. Standard spray sprinklers, by design, have an umbrella like spray pattern that poses a difficult challenge when trying

IMPORTANT

Always refer to Technical Data Sheet TFP700 for the "INSTALLER WARNING" that provides cautions with respect to handling and installation of sprinkler systems and components. Improper handling and installation can permanently damage a sprinkler system or its components and cause the sprinkler to fail to operate in a fire situation or cause it to operate prematurely.

to achieve effective coverage within a shallow space. The Model CC2 Combustible Concealed Space Sprinklers have addressed the difficult "above ceiling" fire challenge for both wet pipe and dry pipe sprinkler systems.

NOTICE

The Model CC2 Combustible Concealed Sprinklers described herein must be installed and maintained in compliance with this document, as well as with the applicable standards of the National Fire Protection Association, in addition to the standards of any other authorities having jurisdiction. Failure to do so may impair the performance of these devices.

The owner is responsible for maintaining their fire protection system and devices in proper operating condition. Contact the installing contractor or manufacturer with any questions.

Sprinkler Identification Number

TY2189 – Upright, 4.2K
TY3189 – Upright, 5.6K

Technical Data

Approvals

UL Listed.

(Listings and approvals only apply to the service conditions indicated in the Design Criteria sections.)

Maximum Working Pressure

175 psi (12,1 bar)

Pipe Thread Connection

1/2 inch NPT or ISO 7-R3/4

Discharge Coefficient

K = 4.2 gpm/psi^{1/2} (60,5 lpm/bar^{1/2})

K = 5.6 gpm/psi^{1/2} (80,6 lpm/bar^{1/2})



Temperature Rating
175° F (79° C)

Finish
Natural Brass

Physical Characteristics

Frame	Brass
Button	Bronze
Sealing Assembly	Stainless Steel w/ TEFLON
Bulb	Glass (3 mm dia.)
Compression Screw	Brass
Deflector	Bronze

Operation

The glass bulb contains a fluid that expands when exposed to heat. When the rated temperature is reached, the fluid expands sufficiently to shatter the glass bulb allowing the sprinkler to activate and flow water.

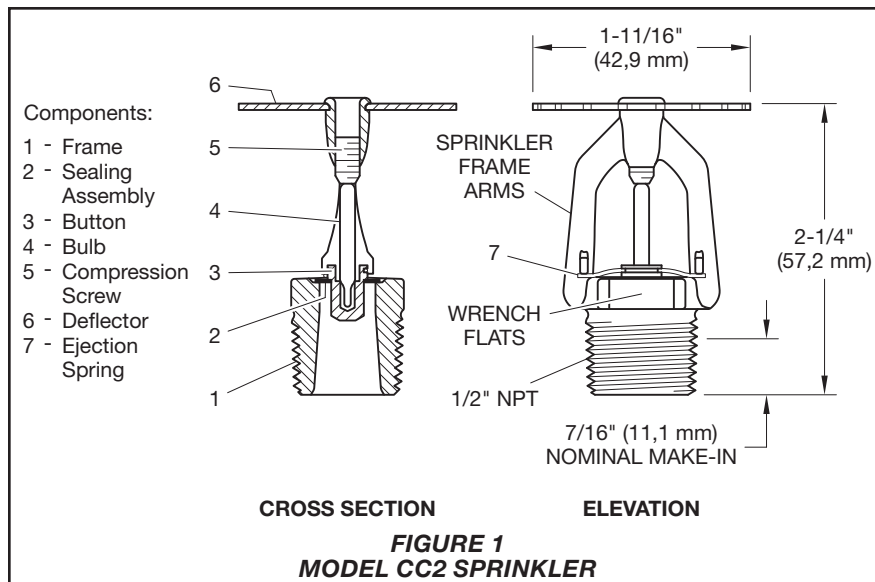

Design Criteria

Design criteria is provided as follows:

- 175° F (79° C), Model CC2 Combustible Concealed Sprinklers with CPVC Pipe and horizontal slope above sprinklers not exceeding 2:12 (Refer to Page 2).
- 175° F (79° C), Model CC2 Combustible Concealed Sprinklers with Steel Pipe and horizontal slope above sprinklers not exceeding 2:12 (Refer to Page 3).

CPVC Pipe

CC2 Temperature Rating (CPVC Pipe)

175° F (79° C)

Area Of Use (CPVC Pipe)

Horizontal (slope not exceeding 2:12) combustible concealed spaces of:

- Unobstructed wood truss construction or unobstructed bar joist construction (Fig. 2).
- Non-combustible, insulation-filled solid wood or composite wood joist construction (Fig. 3).

NOTE: In order to be considered "non-combustible insulation-filled solid wood or composite wood joist construction," the insulation (including insulation provided with a combustible vapor barrier), must completely fill the pockets between the joists to the bottom of the joists, and the insulation must be secured in place with metal wire netting. The metal wire netting is intended to hold the insulation in place should the insulation become wetted by the operation of the CC2 Sprinklers in the event of a fire.

Concealed Space Area (CPVC Pipe)

The area of the concealed space is not limited; however, for both Fig. 2 and Fig. 3, where CPVC pipe is being utilized, draft-curtains or full height walls must be provided at 1000 ft² (93 m²) areas. This draft curtain shall be at least 1/3 the depth of the concealed space or 8 inches (200 mm), whichever is greater, and be constructed using a material that will not allow heat to escape through or above the draft curtain.

Concealed Space Size (CPVC Pipe)

The depth of the concealed space is 36 inches (915 mm) maximum to 12 inches (305 mm) minimum.

System Type (CPVC Pipe)

Light hazard, wet pipe system

Minimum Distance Between CC2 Sprinklers (CPVC Pipe)

The minimum distance between sprinklers is 7 Ft. (2,1 m).

NOTE: Minimum spacing does not apply to any additional sprinklers required for protection of BlazeMaster CPVC that is offset over an obstruction.

Maximum Distance Between CC2 Sprinklers (CPVC Pipe)

12 feet (3,7 m)

Maximum Coverage Area (CPVC Pipe)

144 ft² (13,4 m²)

Deflector Position (CPVC Pipe)

- 1-1/2 to 4 inches (40 to 100 mm) below upper deck for wood truss construction or bar joist construction (Fig. 2)
- 1-1/2 to 4 inches (40 to 100 mm) below solid wood or composite wood joists (Fig. 3)

Minimum Distance Away From Trusses (CPVC Pipe)

4-1/2 inches (114 mm)

Remote Area (CPVC Pipe)

The remote area is 1000 ft² (93 m²)

NOTE: The remote area does not include any additional sprinklers required for protection of BlazeMaster CPVC that is offset over an obstruction.

Required Density (CPVC Pipe)

0.10 gpm/ft² (4,1 mm/min)

Minimum Operating Pressure (CPVC Pipe)

7 psi (0,48 bar)

NOTE: The minimum resulting flow for the 4.2K is 11.1 gpm, and the minimum resulting flow for the 5.6K is 14.8 gpm. Therefore, for coverage areas less than the maximum permitted coverage area of 144 ft², the 4.2K may provide a hydraulic advantage. The use of the CC1 sprinkler having a K-factor of 2.8, minimum operating pressure of 10 psi, and resulting minimum flow of 9.5 gpm may provide a further hydraulic advantage for yet smaller coverage areas. The CC1 is described in Technical Data Sheet TFP630.

Obstructions (CPVC Pipe)

All obstruction criteria per NFPA for standard spray sprinklers apply (Ref. Figure 8), unless modified by this Technical Data Sheet.

Use Of UL Listed BlazeMaster CPVC Piping With Model CC2 Sprinklers

Only BlazeMaster CPVC product may be used in concealed spaces requiring automatic sprinklers, when used in conjunction with Model CC2 Sprinklers. In order to use the BlazeMaster CPVC product for wood truss or bar joist construction, the horizontal run of pipe must be a maximum of 6 Inches (150 mm) above the ceiling or non-combustible ceiling insulation, or 1/3 the depth of concealed space (as measured from the top surface of the ceiling to the bottom of the deck above), whichever is smaller (Fig. 2). For insulation filled solid wood or composite wood joist construction, the horizontal run of pipe must be a maximum of 6 Inches (150 mm) above ceiling or non-combustible ceiling insulation, or 1/3 the depth of concealed space (as measured from the top surface of the ceiling to the bottom surface of the joist insulation above), whichever is smaller (Fig. 3). The CPVC piping can then be used to supply the Model CC2 Sprinklers, as well as the sprinklers below the ceiling. Unless modified by this Technical Data Sheet, all

other guidelines of the “BlazeMaster — Installation Instructions & Technical Manual” must be met. When using 1 inch (DN25) or larger pipe, a hanger must be located at the truss nearest a sprig for purposes of restraint. If using 3/4 inch (DN19) piping, all sprigs over 12 inches (305 mm) must be laterally braced using methods described in the NFPA standards.

Where the CPVC must be offset up and over an obstruction and the pipe exceeds the allowed horizontal positioning requirements specified above as well as shown in Figure 2 and 3, additional Model CC2 Sprinklers are to be installed as shown in Figure 2 and 3 to protect the BlazeMaster CPVC product.

A minimum lateral distance of 18 inches (460 mm) must be maintained between the CPVC pipe and heat pumps, fan motors, and heat lamps.

Steel Pipe

CC2 Temperature Rating (Steel Pipe)

175° F (79° C)

Area Of Use (Steel Pipe)

Horizontal (slope not exceeding 2:12) combustible concealed spaces of

- Unobstructed wood truss construction or unobstructed bar joist construction (Fig. 4)
- Solid wood joist construction (Fig. 5) where the upper deck and ceiling joists may have a maximum depth of 12 inches (300 mm) and typical on center joist spacing of minimum 16 inches (400 mm)
- Non-combustible insulation filled solid wood joist or wood composite joist construction (Fig. 6)
- Obstructed wood truss construction (Fig. 7)

NOTE: In order to be considered “non-combustible insulation filled solid wood joist or composite wood joist construction”, the insulation (including insulation provided with a combustible vapor barrier), must completely fill the pockets between the joists to the bottom of the joists, and the insulation must be secured in place with metal wire netting. The metal wire netting is intended to hold the insulation in place should the insulation become wetted by the operation of the CC2 Sprinklers in the event of a fire.

Concealed Space Area (Steel Pipe)

The area of the concealed space is not limited; however,

- for unobstructed wood truss construction or concealed spaces of non-combustible, unobstructed

bar joist construction (Fig. 4) draft-curtains or full height walls must be provided at 1000 ft² (93 m²) areas. This draft curtain shall be at least 1/3 the depth of the concealed space or 8 inches (200 mm), whichever is greater, and be constructed using a material that will not allow heat to escape through or above the draft curtain.

- for solid wood joist construction (Fig. 5) and obstructed wood truss construction (Fig. 7), blocking must be provided in each upper deck and ceiling joist channel at a maximum 32 feet (9,75 m) intervals. This blocking shall be installed to the full depth of the joists and be installed so as to not allow heat to escape through or above the blocking. The blocking must be constructed using a non-combustible material or the joist construction material.

Draft curtains must protrude below the joist a minimum of 6 inches (150 mm) or 1/3 the space, whichever is greatest, and run parallel with the joist spaced at 31 feet (9,4 m) width maximum to limit the area to a maximum of 1000 ft² (93 m²). The draft curtain may be constructed of 1/4 inch (6,4 mm) plywood to prevent heat from escaping beyond the area.

- For non-combustible, insulation-filled solid wood joist or composite wood joist construction (Fig. 6), the requirement for draft curtains or blocking does not apply.

Concealed Space Size (Steel Pipe)

The minimum and maximum concealed space depth is as follows:

For unobstructed wood truss construction or concealed spaces of unobstructed bar joist construction (Fig. 4) the depth of the concealed space is 36 inches (915 mm) maximum to 12 inches (305 mm) minimum.

For solid wood joist construction (Fig. 5), solid wood or composite wood joist construction filled with non-combustible insulation (Fig. 6), or obstructed wood truss construction (Fig. 7), the maximum depth of the concealed space is 54 inches from bottom of upper deck to top of ceiling, and the minimum depth is 6 inches from the bottom of the upper deck joists to the top of the ceiling joists.

System Type (Steel Pipe)

Light hazard, wet or dry pipe system using steel pipe.

NOTES: Use of the 4.2K sprinklers in dry pipe systems is permitted by section 8.3.4.3 of NFPA 13 (2007 edition) where piping is corrosion resistant or internally galvanized.

Minimum Distance Between CC2 Sprinklers (Steel Pipe)

7 feet (2,1 m)

Maximum Distance Between CC2 Sprinklers (Steel Pipe)

12 feet (3,7 m)

Maximum Coverage Area (Steel Pipe)

144 ft² (13,4 m²)

Deflector Position (Steel Pipe)

1-1/2 to 4 inches (40 to 100 mm) below upper deck for wood truss construction or concealed spaces of non-combustible bar joist construction (Fig. 4)

1-1/2 to 2 inches (40-50 mm) below solid wood joist (Fig. 5) or top chord of a wood truss that has a depth greater than 4 inches

1-1/2 to 4 inches (40 to 100 mm) below non-combustible insulation filled solid wood joists or composite wood joists (Fig. 6)

Remote Area (Steel Pipe)

The remote area for wood truss construction or bar joist construction (Fig. 4) or solid wood joist construction (Fig. 5) is 1000 ft² (93 m²) for wet pipe systems or 1300 ft² (121 m²) for dry pipe systems.

The remote area for non-combustible insulation filled solid wood joist or wood composite joist construction (Fig. 6) is to be calculated per the requirements of NFPA 13.

Required Density (Steel Pipe)

0.10 gpm/ft² (4,1 mm/min)

Minimum Operating Pressure (Steel Pipe)

7 psi (0,48 bar)

Note: The minimum resulting flow for the 4.2K is 11.1 gpm, and the minimum resulting flow for the 5.6K is 14.8 gpm. Therefore, for coverage areas less than the maximum permitted coverage area of 144 ft², the 4.2K may provide a hydraulic advantage. The use of the CC1 sprinkler having a K factor of 2.8, minimum operating pressure of 10 psi, and resulting minimum flow of 9.5 gpm may provide a further hydraulic advantage for yet smaller coverage areas when designing wet pipe systems. The CC1 is described in Technical Data Sheet TFP630.

Obstructions (Steel Pipe)

All obstruction criteria per NFPA for standard spray sprinklers apply (Ref. Figure 9), unless modified by this Technical Data Sheet.

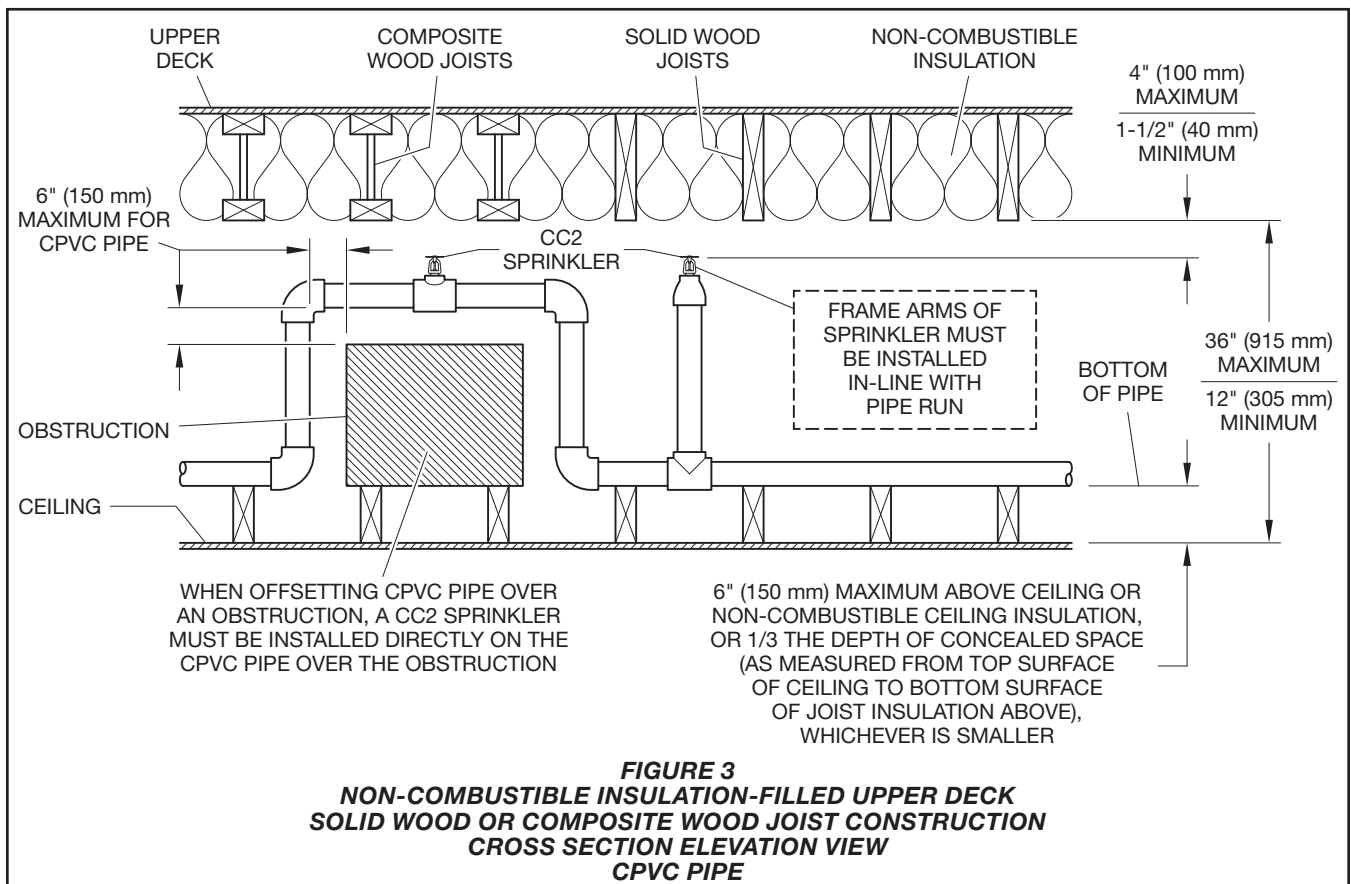
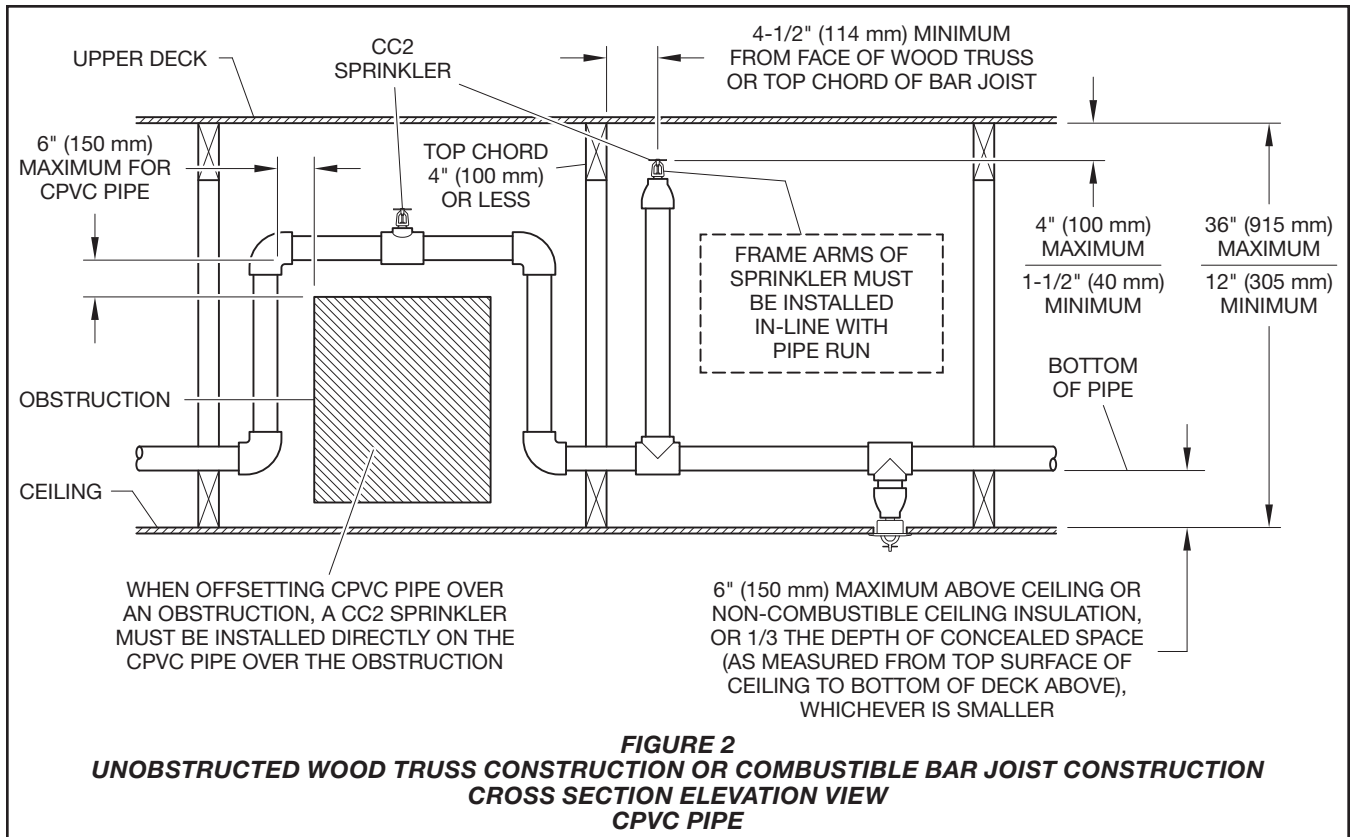

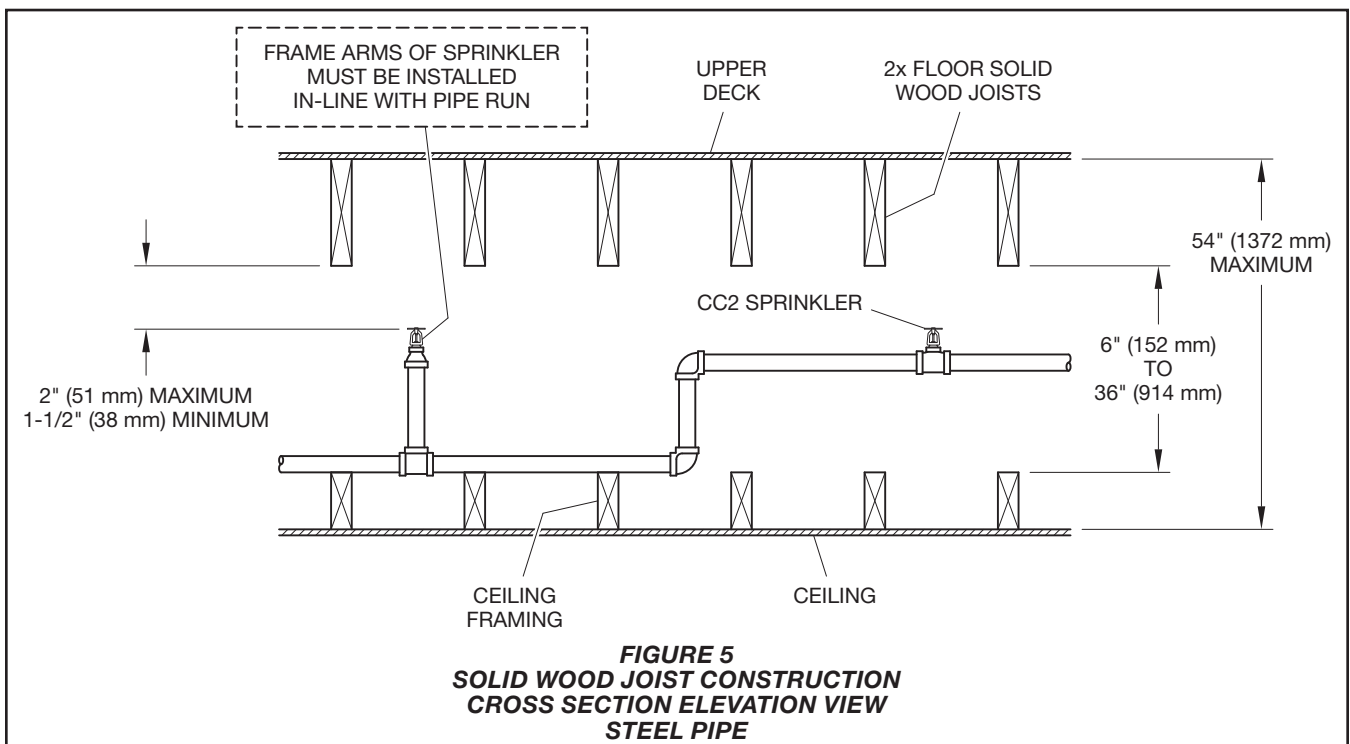
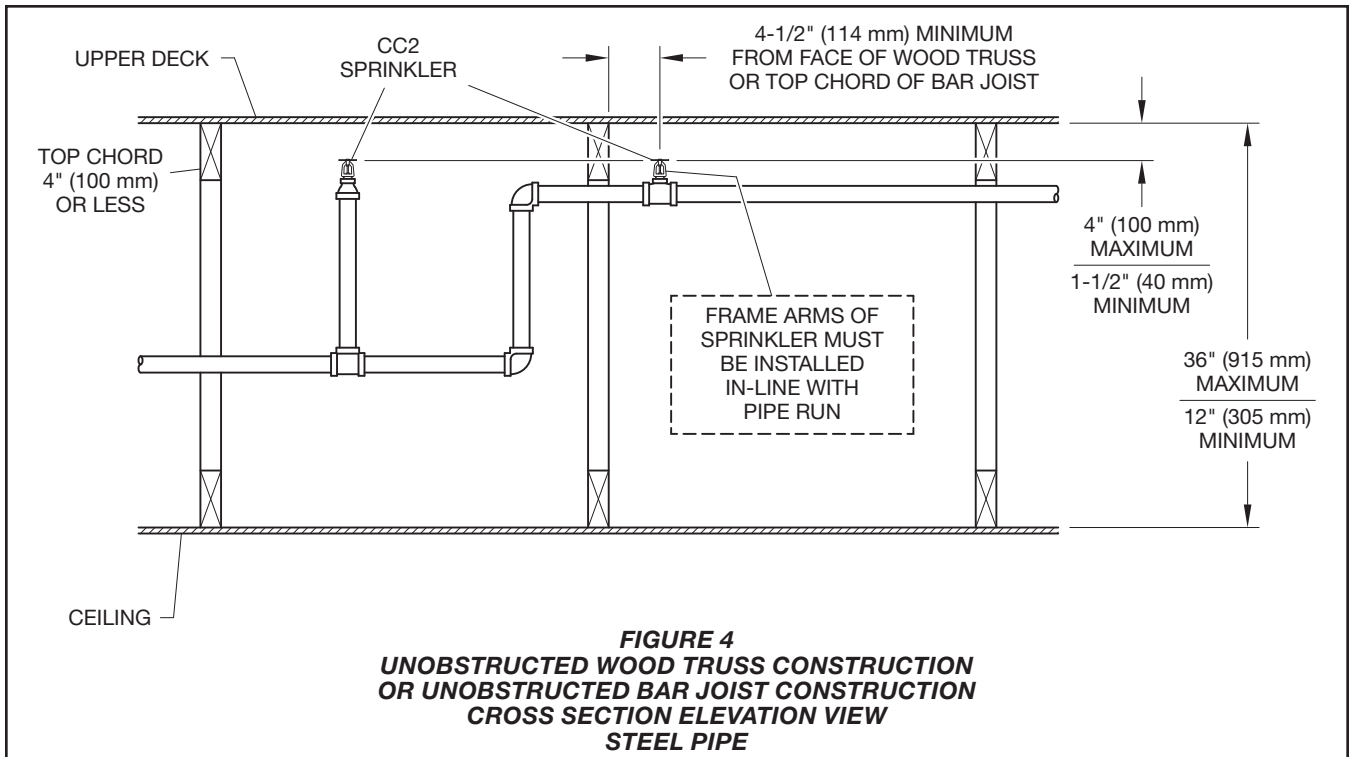

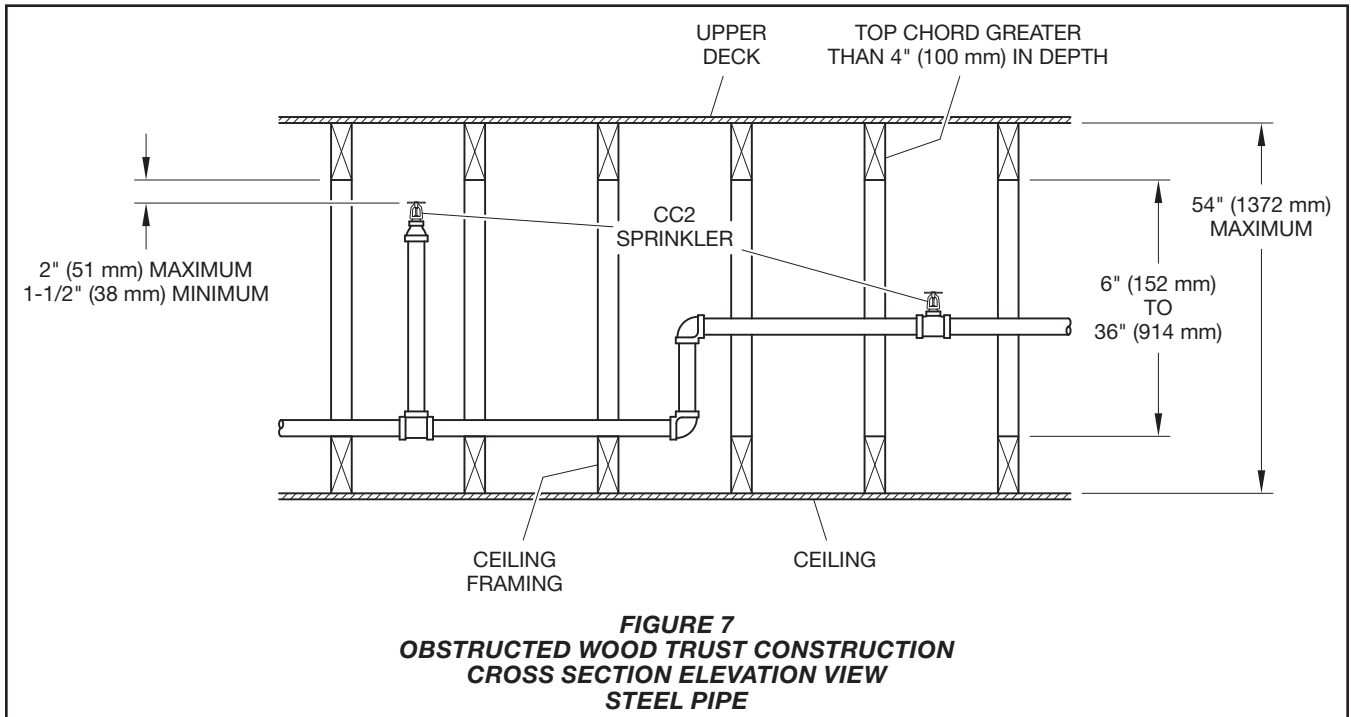
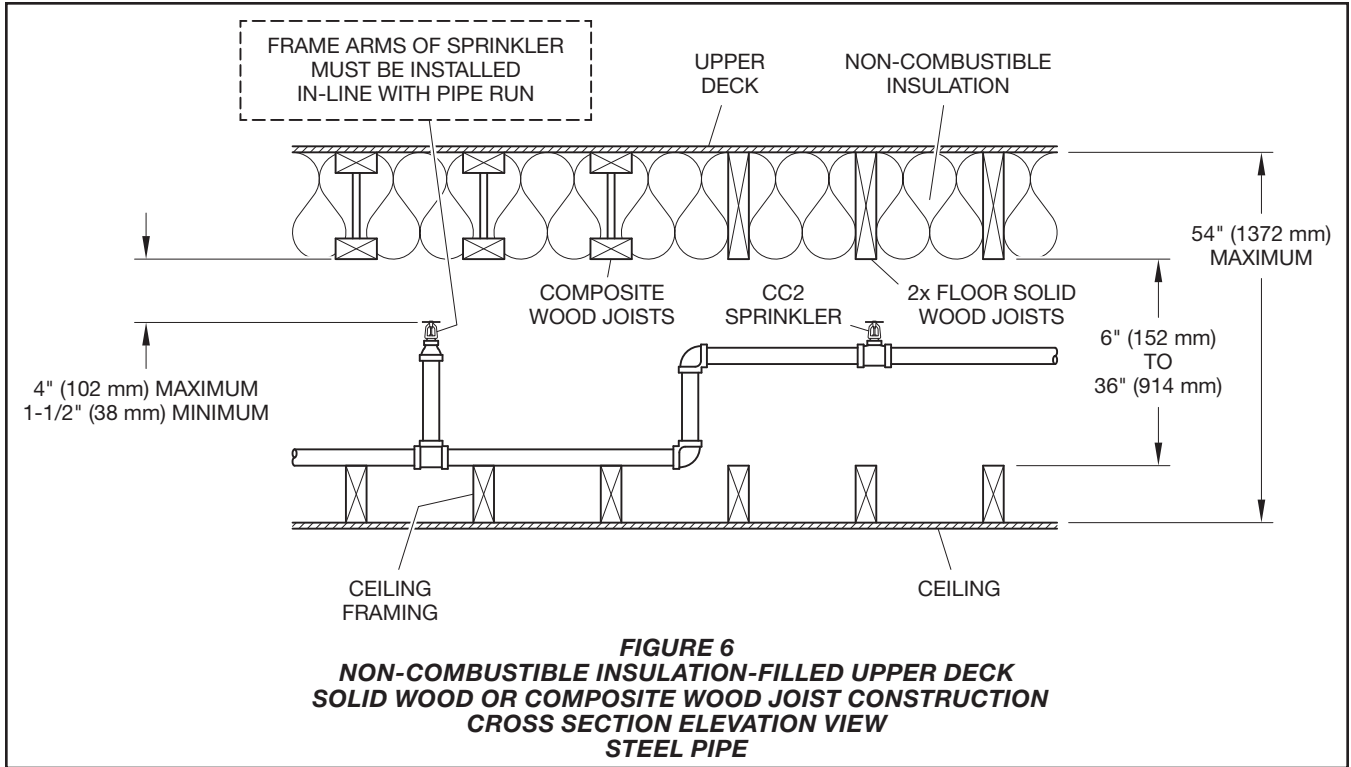

Installation

The Model CC2 Sprinklers must be installed in accordance with this section.

General instructions

The CC2 Sprinklers are to be installed upright and with their frame arms in-line with the pipe run (reference Figures 1 - 9, as applicable).

Do not install any bulb type sprinkler if the bulb is cracked or there is a loss of liquid from the bulb. With the sprinkler held horizontally, a small air bubble should be present. The diameter of the air bubble is approximately 1/16 inch (1,6 mm) for the 175° F (79° C) temperature rating.

A leak tight 1/2 inch NPT sprinkler joint should be obtained with a torque of 7 to 14 ft.-lbs. (9,5 to 19,0 Nm). Higher levels of torque may distort the sprinkler inlet with consequent leakage or impairment of the sprinkler.

The Model CC2 Sprinklers must only be installed in the upright position with the deflector parallel to the upper deck. With pipe thread sealant applied to the pipe threads, use only the W-Type 6 (End A) Sprinkler Wrench (Fig. 9) for installation of the Model CC2 Sprinklers by applying the wrench to the sprinkler wrench flats only.

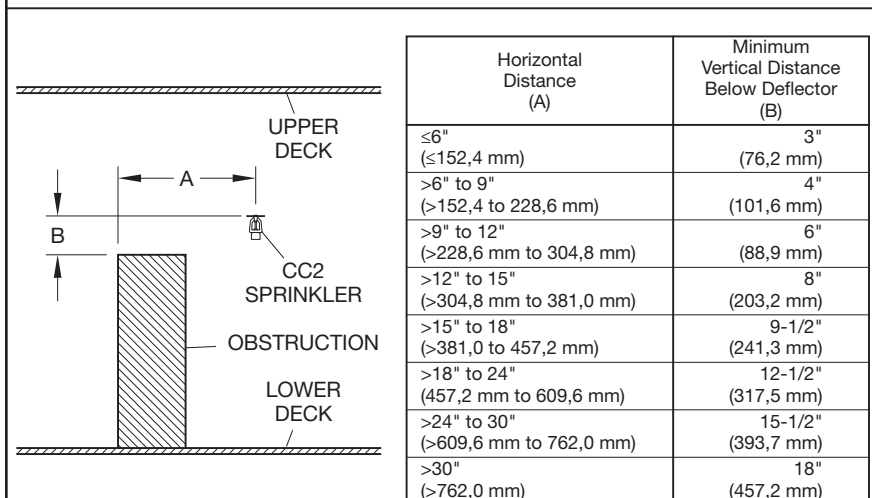
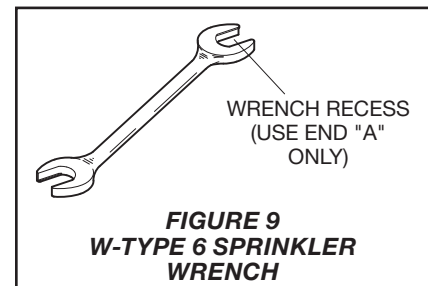
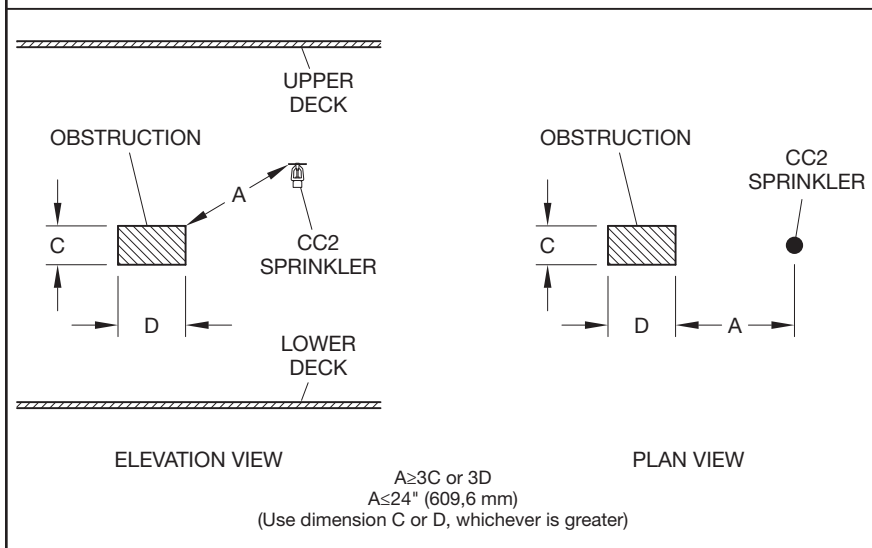
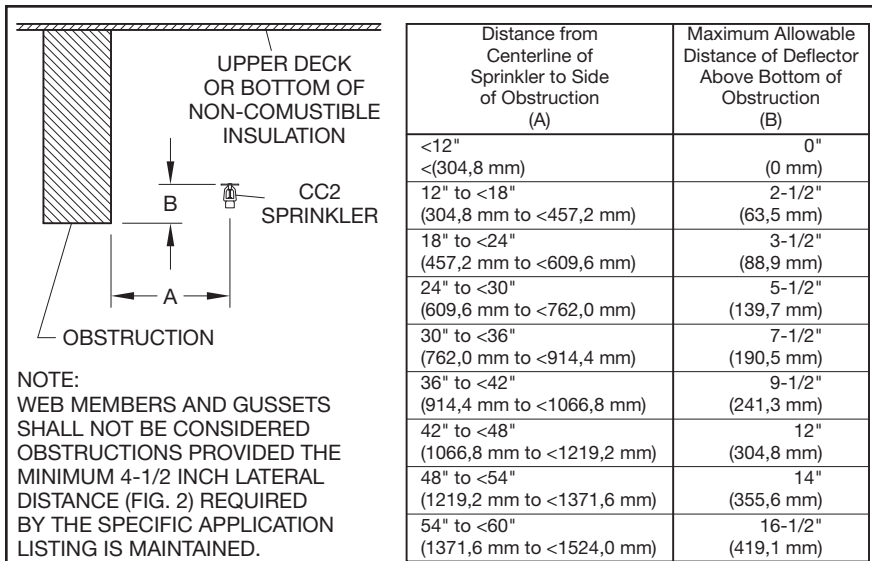

**FIGURE 8
NFPA 13 OBSTRUCTION TO WATER DISTRIBUTION CRITERIA
(REFERENCE)**

Care and Maintenance

The Model CC2 Sprinklers must be maintained and serviced in accordance with this section.

Before closing a fire protection system main control valve for maintenance work on the fire protection system that it controls, permission to shut-down the affected fire protection systems must be obtained from the proper authorities and all personnel who may be affected by this action must be notified.

Sprinklers that are found to be leaking or exhibiting visible signs of corrosion must be replaced.

Automatic sprinklers must never be painted, plated, coated, or otherwise altered after leaving the factory. Modified sprinklers must be replaced. Sprinklers that have been exposed to corrosive products of combustion, but have not operated, should be replaced if they cannot be completely cleaned by wiping the sprinkler with a cloth or by brushing it with a soft bristle brush.

Care must be exercised to avoid damage to the sprinklers before, during, and after installation. Sprinklers damaged by dropping, striking, wrench twist/slippage, or the like, must be replaced. Also, replace any sprinkler that has a cracked bulb or that has lost liquid from its bulb. (Ref. Installation Section).

The owner is responsible for the inspection, testing, and maintenance of their fire protection system and devices in compliance with this document, as well as with the applicable standards of the National Fire Protection Association (e.g., NFPA 25), in addition to the standards of any other authorities having jurisdiction. Contact the installing contractor or sprinkler manufacturer with any questions.

It is recommended that automatic sprinkler systems be inspected, tested, and maintained by a qualified Inspection Service in accordance with local requirements and/or national codes.

Limited Warranty

For warranty terms and conditions, visit www.tyco-fire.com.

Ordering Procedure

Contact your local distributor for availability. When placing an order, indicate the full product name and Part Number (P/N).

Sprinkler Assemblies with NPT Thread Connections

Specify: SIN (specify), K-factor (specify), Model CC2, 175° F (79° C), Upright, Specific Application, Combustible Concealed Space Sprinkler, P/N (specify)

TY2189, 4.2K 51-311-1-175
TY3189, 5.6K 51-301-1-175

Sprinkler Wrench:

Specify: W-Type 6 Sprinkler Wrench, P/N 56-000-6-387