

## Series TY-FRL — 2.8, 5.6, and 8.0 K-factor Upright, Pendent, and Recessed Pendent Sprinklers Quick Response, Standard Coverage

### General Description

The TYCO Series TY-FRL, 2.8, 5.6, and 8.0 K-factor, Upright and Pendent Sprinklers described in this data sheet are quick response, standard coverage, solder type spray sprinklers designed for use in light and ordinary hazard commercial occupancies such as banks, hotels, shopping malls, schools, hospitals, etc.

The recessed version of the 2.8 and 5.6 K-factor, Series TY-FRL Pendent Sprinkler, where applicable, is intended for use in areas with a finished ceiling. It uses a two-piece Style 20 (1/2 inch NPT) Recessed Escutcheon. The Recessed Escutcheon provides 1/4 inch (6,4 mm) of recessed adjustment or up to 1/2 inch (12,7 mm) of total adjustment from the flush pendent position. The adjustment provided by the Recessed Escutcheon reduces the accuracy to which the fixed pipe drops to the sprinklers must be cut.

An intermediate level version of the 5.6 and 8.0 K-factor, Series TY-FRL Pendent Sprinkler can be obtained by utilizing the Series TY-FRL Pendent Sprinkler in combination with the Model S4 Shield.

#### IMPORTANT

Always refer to Technical Data Sheet TFP700 for the "INSTALLER WARNING" that provides cautions with respect to handling and installation of sprinkler systems and components. Improper handling and installation can permanently damage a sprinkler system or its components and cause the sprinkler to fail to operate in a fire situation or cause it to operate prematurely.

#### NOTICE

The Series TY-FRL Sprinklers described herein must be installed and maintained in compliance with this document, as well as with the applicable standards of the National Fire Protection Association, in addition to the standards of any other authorities having jurisdiction. Failure to do so may impair the performance of these devices.

The owner is responsible for maintaining their fire protection system and devices in proper operating condition. Contact the installing contractor or sprinkler manufacturer with any questions.

### Sprinkler Identification Numbers

TY1121. . . . . Upright 2.8K, 1/2" NPT  
TY1221 . . . . . Pendent 2.8K, 1/2" NPT  
TY3121 . . . . . Upright 5.6K, 1/2" NPT  
TY3221 . . . . . Pendent 5.6K, 1/2" NPT  
TY4121. . . . . Upright 8.0K, 3/4" NPT  
TY4221 . . . . . Pendent 8.0K, 3/4" NPT

TY1121 is a redesignation for S1879 and G8973.

TY1221 is a redesignation for S1880 and G8971.

TY3121 is a redesignation for S1864 and G8974.

TY3221 is a redesignation for S1865 and G8972.

TY4121 is a redesignation for S1866 and G8174.

TY4221 is a redesignation for S1867 and G8172.



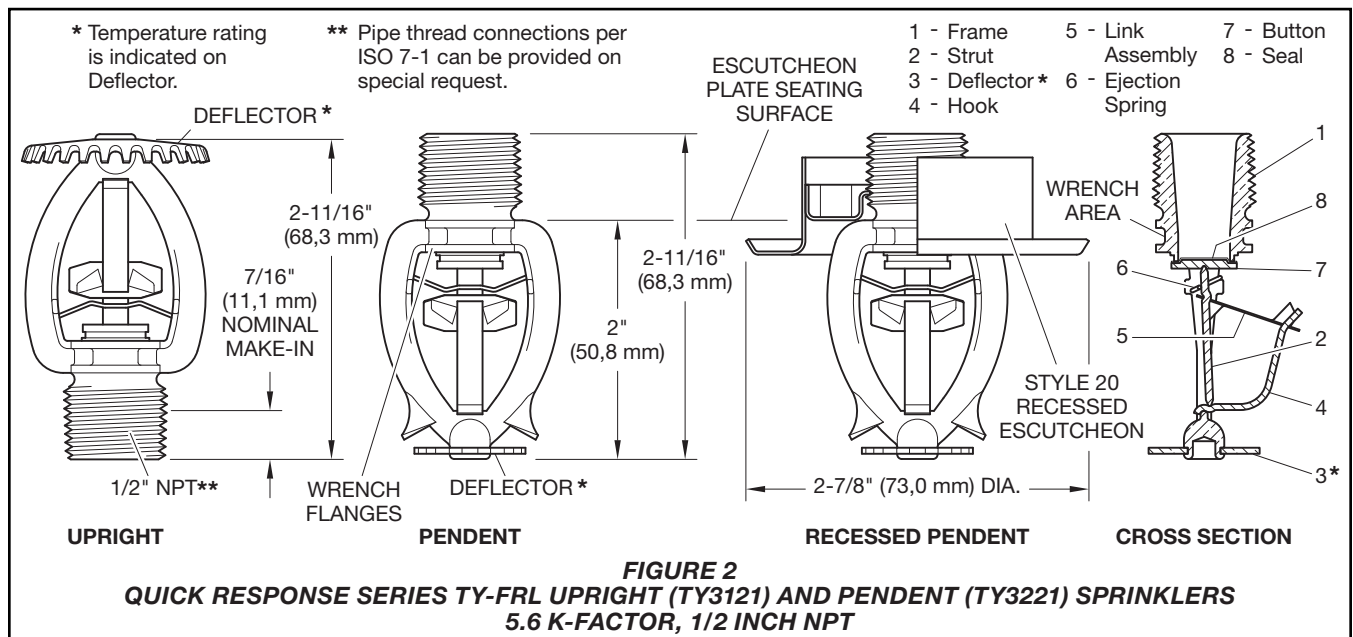
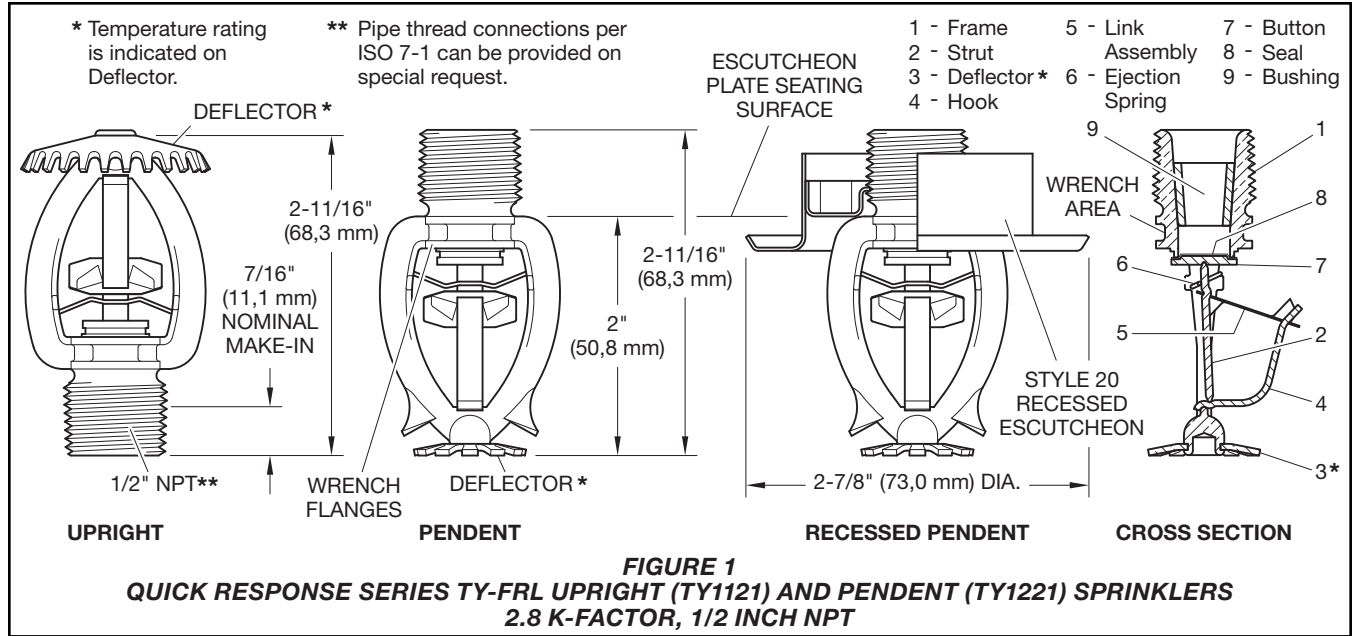

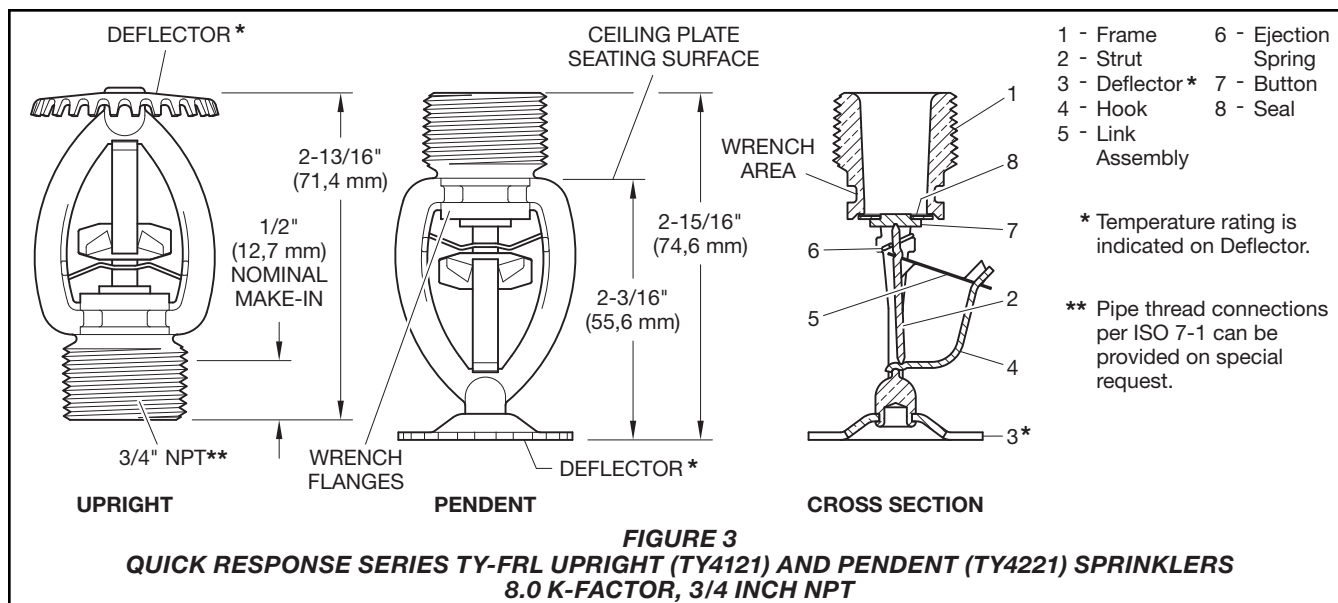

## Technical Data

### Approvals

UL and C-UL Listed. FM, NYC, and LPCB Approved. (Refer to Table A for complete approval information including corrosion resistant status.)

### Maximum Working Pressure

175 psi (12,1 bar)

### Discharge Coefficient

K = 2.8 GPM/psi<sup>1/2</sup> (40,3 LPM/bar<sup>1/2</sup>)  
K = 5.6 GPM/psi<sup>1/2</sup> (80,6 LPM/bar<sup>1/2</sup>)  
K = 8.0 GPM/psi<sup>1/2</sup> (115,2 LPM/bar<sup>1/2</sup>)

### Temperature Ratings

Refer to Table A

### Finishes

Sprinkler: Refer to Table A

Recessed Escutcheon: White Coated, Chrome Plated, or Brass Plated

### Physical Characteristics

|                               |         |
|-------------------------------|---------|
| Frame . . . . .               | Bronze  |
| Strut . . . . .               | Monel   |
| Deflector . . . . .           | Bronze  |
| Hook . . . . .                | Monel   |
| Link Assembly . . . . .       | Nickel  |
| Ejection Spring . . . . .     | Inconel |
| Button . . . . .              | Bronze  |
| Seal . . . . .                | TEFLON  |
| Bushing (2.8K only) . . . . . | Brass   |

## Operation

The fusible link (heat collector) assembly is comprised of two halves that are joined together by a thin layer of solder. When the rated temperature is reached, the solder melts and the two link halves separate, allowing the sprinkler to operate.

## Design Criteria

The TYCO Series TY-FRL Pendent and Upright Sprinklers are intended for fire protection systems designed in accordance with the standard installation rules recognized by the applicable Listing or Approval agency (e.g., UL Listing is based on the requirements of NFPA 13, and FM Approval is based on the requirements of FM's Loss Prevention Data Sheets). Only the Style 20 Recessed Escutcheon, as applicable, is to be used for recessed pendent installations.

## Installation

The TYCO Series TY-FRL Sprinklers must be installed in accordance with this section.

A leak tight 1/2 inch NPT sprinkler joint should be obtained with a torque of 7 to 14 ft./lbs. (9,5 to 19,0 Nm). A leak tight 3/4 inch NPT sprinkler joint should be obtained with a torque of 10 to 20 ft./lbs. (13,4 to 26,8 Nm). Higher levels of torque may distort the sprinkler inlet and cause leakage or impairment of the sprinkler.

Do not attempt to make-up for insufficient adjustment in the escutcheon plate by under- or over-tightening the sprinkler. Readjust the position of the sprinkler fitting to suit.

### Series TY-FRL Pendent and Upright Sprinkler Installation

The Series TY-FRL Pendent and Upright Sprinklers must be installed in accordance with this section.

**Step 1.** Pendent sprinklers are to be installed in the pendent position, and upright sprinklers are to be installed in the upright position.

**Step 2.** With pipe thread sealant applied to the pipe threads, hand tighten the sprinkler into the sprinkler fitting.

**Step 3.** Tighten the sprinkler into the sprinkler fitting using only the W-Type 9 Sprinkler Wrench (Ref. Figure 6). With reference to Figures 1, 2, and 3, the W-Type 9 Sprinkler Wrench is to be applied to the wrench area.

| K  | TYPE  | TEMP. RATING  | FRAME COLOR CODE | SPRINKLER FINISH |               |
|--|---|---------------|------------------|------------------|---------------|
|  |   |               |                  | NATURAL BRASS    | CHROME PLATED |
| 2.8<br>1/2"<br>NPT   | <b>PENDENT (TY1221)</b>                     | 165°F (74°C)  | Unpainted        | 1, 2, 5          |               |
|  |   | 212°F (100°C) | White            |                  |               |
|  | <b>UPRIGHT (TY1121)</b>                     | 165°F (74°C)  | Unpainted        |                  |               |
|  |   | 212°F (100°C) | White            |                  |               |
|  | <b>RECESSED PENDENT (TY1221 w/Style 20)</b> | 165°F (74°C)  | Unpainted        |                  |               |
|  |   | 212°F (100°C) | White            |                  |               |
| 5.6<br>1/2"<br>NPT   | <b>PENDENT (TY3221)</b>                     | 165°F (74°C)  | Unpainted        | 1, 2, 3, 4, 5    |               |
|  |   | 212°F (100°C) | White            | 1, 2, 3, 5       |               |
|  | <b>UPRIGHT (TY3121)</b>                     | 165°F (74°C)  | Unpainted        | 1, 2, 3, 4, 5    |               |
|  |   | 212°F (100°C) | White            | 1, 2, 3, 5       |               |
|  | <b>RECESSED PENDENT (TY3221 w/Style 20)</b> | 165°F (74°C)  | Unpainted        | 1, 2, 5          |               |
|  |   | 212°F (100°C) | White            |                  |               |
| 8.0<br>3/4"<br>NPT   | <b>PENDENT (TY4221)</b>                     | 165°F (74°C)  | Unpainted        | 1, 2, 3, 5       |               |
|  |   | 212°F (100°C) | White            |                  |               |
|  | <b>UPRIGHT (TY4121)</b>                     | 165°F (74°C)  | Unpainted        |                  |               |
|  |   | 212°F (100°C) | White            |                  |               |
| <p><b>NOTES:</b></p> <p>(1) Listed by Underwriters Laboratories, Inc. (UL) as Quick Response Sprinklers</p> <p>(2) Listed by Underwriters Laboratories, Inc. for use in Canada (C-UL) as Quick Response Sprinklers.</p> <p>(3) Approved by Factory Mutual Research Corporation (FM) as Quick Response Sprinklers.</p> <p>(4) Approved by the Loss Prevention Certification Board (LPCB Ref. No. 094a/03) as Quick Response Sprinklers.</p> <p>(5) Approved by the City of New York under MEA 112-04-E.</p> <p style="text-align: center;"><b>TABLE A</b><br/> <b>LABORATORY LISTINGS AND APPROVALS</b></p> |   |               |                  |                  |               |

**Series TY-FRL Recessed Pendent Sprinkler Installation**

The Series TY-FRL Recessed Pendent Sprinklers must be installed in accordance with the following instructions.

**Step A.** After installing the Style 20 Mounting Plate, as applicable, over the sprinkler threads and with pipe thread sealant applied to the pipe threads, hand tighten the sprinkler into the sprinkler fitting.

**Step B.** Tighten the sprinkler into the sprinkler fitting using only the W-Type 12 Recessed Sprinkler Wrench (Ref. Figure 7). With reference to Figure 1, or 2, the W-Type 12 Recessed Sprinkler Wrench is to be applied to the sprinkler wrenching flanges.

**Step C.** After the ceiling has been installed or the finish coat has been applied, slide on the Style 20 Escutcheon over the Series TY-FRL Sprinkler and push the Escutcheon over the Mounting Plate until its flange comes in contact with the ceiling.

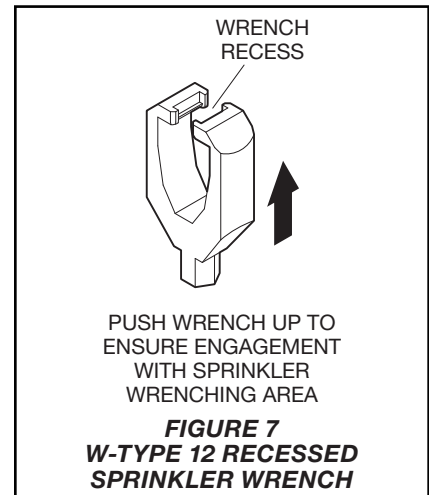
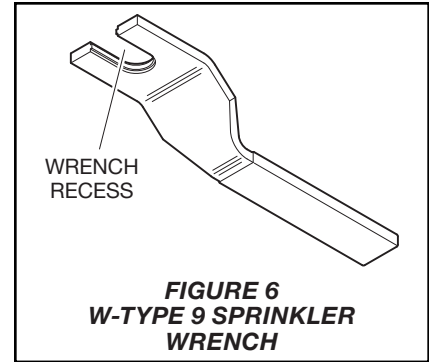
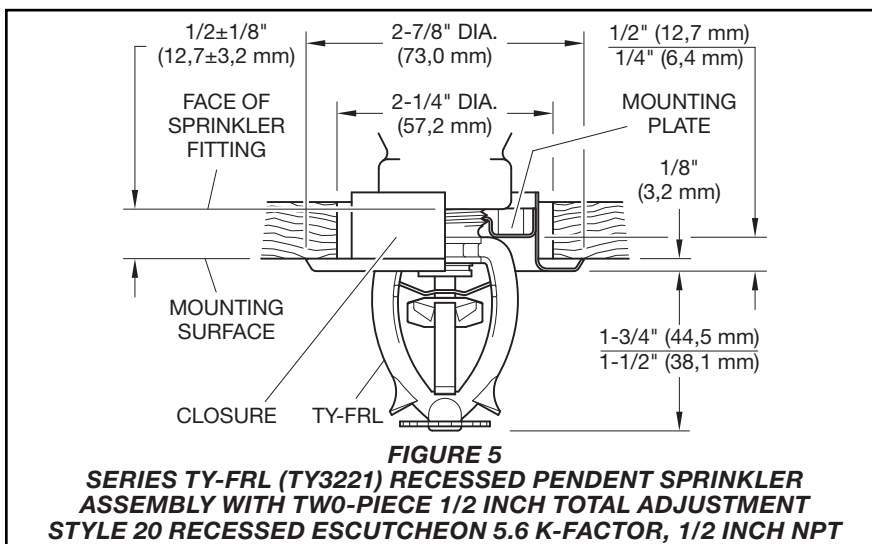
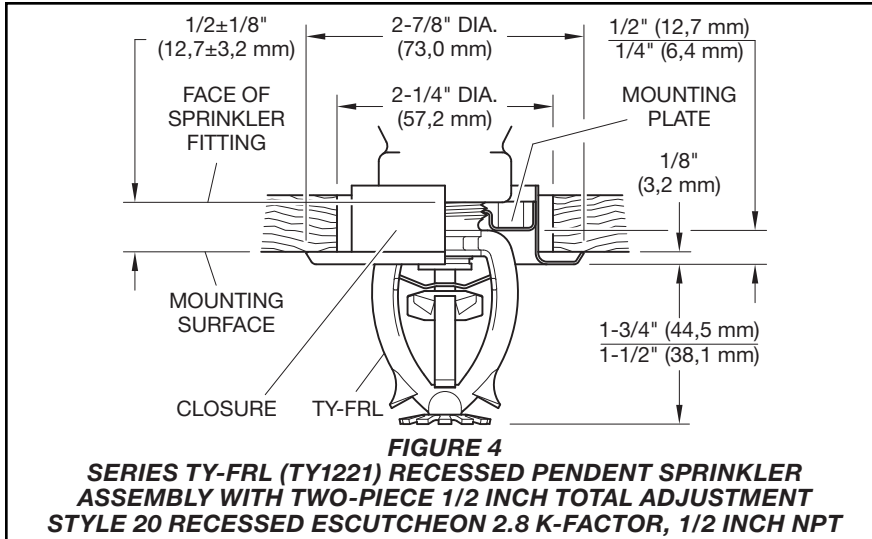

## Care and Maintenance

The TYCO Series TY-FRL Sprinklers must be maintained and serviced in accordance with this section.

Before closing a fire protection system main control valve for maintenance work on the fire protection system that it controls, permission to shut down the affected fire protection system must be obtained from the proper authorities and all personnel who may be affected by this action must be notified.

Absence of an escutcheon, which is used to cover a clearance hole, may delay the time to sprinkler operation in a fire situation.

Sprinklers that are found to be leaking or exhibiting visible signs of corrosion must be replaced.

Automatic sprinklers must never be painted, plated, coated or otherwise altered after leaving the factory. Modified or over-heated sprinklers must be replaced.

Care must be exercised to avoid damage to the sprinklers -before, during, and after installation. Sprinklers damaged by dropping, striking, wrench twist/slippage, or the like, must be replaced.

The owner is responsible for the inspection, testing, and maintenance of their fire protection system and devices in compliance with this document, as well as with the applicable standards of the National Fire Pro-

tection Association (e.g., NFPA 25), in addition to the standards of any other authorities having jurisdiction. The installing contractor or sprinkler manufacturer should be contacted relative to any questions.

It is recommended that automatic sprinkler systems be inspected, tested, and maintained by a qualified Inspection Service in accordance with local requirements and/or national codes.

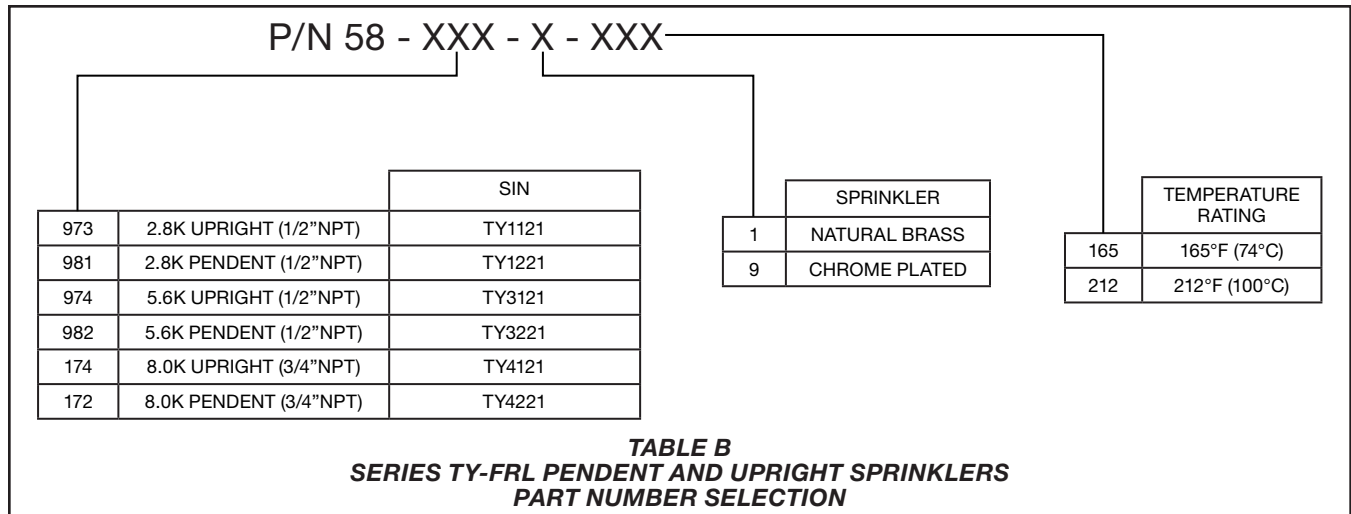

## Ordering Procedure

Contact your local distributor for availability. When placing an order, indicate the full product name and Part Number (P/N).

### Sprinkler Assemblies with NPT Thread Connections

Specify: Series TY-FRL (specify SIN), (specify K-factor), (specify Upright, Pendent, or Recessed Pendent) Sprinkler Quick Response, (specify) temperature rating, (specify type of finish), P/N (specify from Table B)

### Recessed Escutcheon

Specify: Style 20 Recessed Escutcheon with (specify\*) finish, P/N (specify\*)

\*Refer to Technical Data Sheet TFP770

### Sprinkler Wrench

Specify: W-Type 9 Sprinkler Wrench, P/N 56-000-1-849

Specify: W-Type 12 Sprinkler Wrench, P/N 56-798-1-001