

DOUBLE GIMBAL EXPANSION JOINTS



Scan this QR Code



Gimbal type expansion joints are designed to permit angular rotation in any plane by the use of two pairs of hinges affixed to a common floating gimbal ring.

Simply, a double gimbal expansion joint is consisted of two single gimbal expansion joints and an intermediate pipe connects them each other. The advantage of this arrangement is the ability to absorb a large lateral movement in any plane at each end. Because the gimbals are attached to each end of the bellows, the thermal expansion of the intermediate pipe will not be absorbed by the universal but must be accepted by the adjacent piping.

Movement Absorption

This type of expansion joints are used to absorb axial and lateral movements in all planes. The amount of lateral deflection depends on the convolution number of the bellows on each side of the expansion joint. This amount can also be increased by changing the length of the intermediate pipe. Hinges and gimbals provide proper positioning and prevent installation inaccuracies.

Advantages of Double Gimbal Expansion Joints

- Protects the pipeline systems against collapse and breakages by compensating seismic motions (earthquake) and large lateral and angular movements.
- Movement of bellows is more controlled.
- Internal flow liners for eliminating velocity problems may be fitted.
- Anchors only require to absorb spring forces.
- Pressure thrust is restrained by the hardware

DESIGN

Structure

Bellow Material	Stainless Steel AISI 321 (opt.304,316L,316Ti,309)
Connection Types	Fixed and Floating Flanged and Welded End
Flange Material	Carbon Steel St.37.2 as standard, the material can be customised on request
Intermediate Pipe Material	Carbon Steel St.37.2 as standard, the material can be customised on request
Hinge and Gimbal Material	Carbon Steel St.37.2 as standard, the material can be customised on request

Operation Conditions

Operating Temperature	-80°C/+600°C
Operating Pressure	PN 2,5/6/16/25/40/64

Nominal Diameters	DN25 (1") - DN1000 (40")
-------------------	--------------------------

DOUBLE GIMBAL EXPANSION JOINTS

Double Gimbal Expansion Joints, Flanged

Available Types (Standard Versions)

Name	Axial Expansion Amount	Lateral Expansion Amount	Design Pressure	Definition
SISKKF-50	±50mm	±50mm	16 bar	Double Gimbal Expansion Joint with 50mm lateral expansion, flanged
SISKKF-100	±50mm	±100mm	16 bar	Double Gimbal Expansion Joint with 100mm lateral expansion, flanged
SISKKF-150	±50mm	±150mm	16 bar	Double Gimbal Expansion Joint with 150mm lateral expansion, flanged
SISKKF-200	±50mm	±200mm	16 bar	Double Gimbal Expansion Joint with 200mm lateral expansion, flanged

* Special designed Double Gimbal Expansion Joints with customized features are available on request.

** Subject to technical alterations and deviations resulting from the manufacturing process without giving any notification.

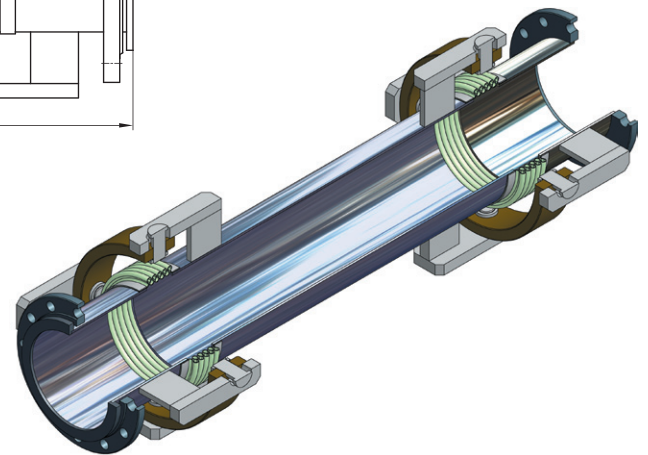
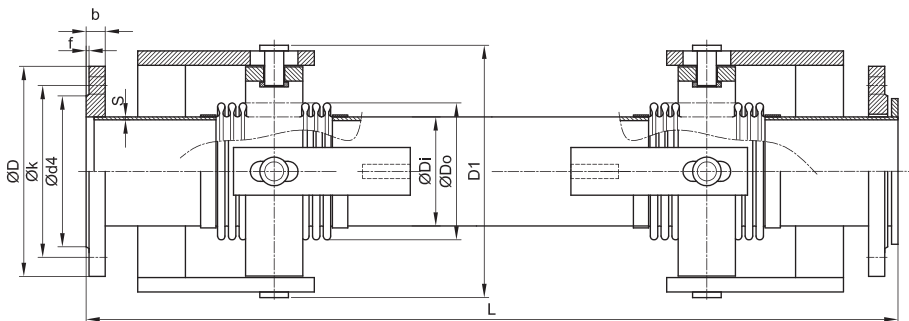

Flange (DIN EN 1092/1) PN 16								
DN	A	ØD	Øk1	k2	Ød4	f	b	Ødxn
DN25	185	115	85	150	68	2	16	Ø14x4
DN32	210	140	100	180	78	2	18	Ø18x4
DN40	220	150	110	185	88	3	18	Ø18x4
DN50	250	165	125	205	102	3	20	Ø18x4
DN65	270	185	145	225	122	3	20	Ø18x4
DN80	310	200	160	251	138	3	20	Ø18x8
DN100	330	220	180	271	158	3	22	Ø18x8
DN125	366	250	210	304	188	3	22	Ø18x8
DN150	420	285	240	347	212	3	24	Ø23x8
DN200	510	340	295	411	268	3	26	Ø23x12
DN250	573	405	355	484	320	3	29	Ø27x12
DN300	660	460	410	555	378	4	32	Ø27x12

All the dimensions in the table are given in "mm".

Other flange types made according to different standards (ANSI, BS, UNI) are also available

DOUBLE GIMBAL EXPANSION JOINTS

Double Gimbal Expansion Joints, Flanged

DN	Bellow			D1	s	SISKKF-50					SISKKF-100				
	ØDi	ØD0	Effective Bellow Area cm ²			Expansion			L	Code	Expansion			L	Code
						± X	± Z	± Y			± X	± Z	± Y		
DN25	38	48,2	14,58	90	2,3	50	50	50	720	702.070.301.002	50	50	100	920	702.070.302.002
DN32	42,2	55	18,62	105	2,6	50	50	50	720	702.070.301.004	50	50	100	920	702.070.302.004
DN40	48,3	61	23,44	115	2,6	50	50	50	720	702.070.301.006	50	50	100	920	702.070.302.006
DN50	60,3	76	36,46	140	2,9	50	50	50	800	702.070.301.008	50	50	100	1000	702.070.302.008
DN65	76,1	95	57,45	160	2,9	50	50	50	800	702.070.301.010	50	50	100	1000	702.070.302.010
DN80	88,9	111	78,42	190	3,2	50	50	50	830	702.070.301.012	50	50	100	1030	702.070.302.012
DN100	114,3	140	137,09	250	3,6	50	50	50	850	702.070.301.014	50	50	100	1050	702.070.302.014
DN125	139,7	164	181,01	285	4	50	50	50	980	702.070.301.016	50	50	100	1180	702.070.302.016
DN150	168,3	200	266,20	350	4,5	50	50	50	980	702.070.301.018	50	50	100	1180	702.070.302.018
DN200	219,1	250	431,86	420	6,3	50	50	50	1140	702.070.301.020	50	50	100	1340	702.070.302.020
DN250	273	323	697,11	480	6,3	50	50	50	1140	702.070.301.022	50	50	100	1340	702.070.302.022
DN300	323,9	380	972,37	540	7,1	50	50	50	1200	702.070.301.024	50	50	100	1400	702.070.302.024

DN	Bellow			D1	s	SISKKF-150					SISKKF-200				
	ØDi	ØD0	Effective Bellow Area cm ²			Expansion			L	Code	Expansion			L	Code
						± X	± Z	± Y			± X	± Z	± Y		
DN25	38	48,2	14,58	90	2,3	50	50	150	1120	702.070.303.002	50	50	200	1320	702.070.304.002
DN32	42,2	55	18,62	105	2,6	50	50	150	1120	702.070.303.004	50	50	200	1320	702.070.304.004
DN40	48,3	61	23,44	115	2,6	50	50	150	1120	702.070.303.006	50	50	200	1320	702.070.304.006
DN50	60,3	76	36,46	140	2,9	50	50	150	1200	702.070.303.008	50	50	200	1420	702.070.304.008
DN65	76,1	95	57,45	160	2,9	50	50	150	1250	702.070.303.010	50	50	200	1500	702.070.304.010
DN80	88,9	111	78,42	190	3,2	50	50	150	1270	702.070.303.012	50	50	200	1500	702.070.304.012
DN100	114,3	140	137,09	250	3,6	50	50	150	1300	702.070.303.014	50	50	200	1550	702.070.304.014
DN125	139,7	164	181,01	285	4	50	50	150	1480	702.070.303.016	50	50	200	1780	702.070.304.016
DN150	168,3	200	266,20	350	4,5	50	50	150	1480	702.070.303.018	50	50	200	1780	702.070.304.018
DN200	219,1	250	431,86	420	6,3	50	50	150	1700	702.070.303.020	50	50	200	2050	702.070.304.020
DN250	273	323	697,11	480	6,3	50	50	150	1700	702.070.303.022	50	50	200	2100	702.070.304.022
DN300	323,9	380	972,37	540	7,1	50	50	150	1750	702.070.303.024	50	50	200	2150	702.070.304.024

All the dimensions in the table are given in "mm".

Double Gimbal Expansion Joints, Welded End

Available Types (Standard Versions)

Name	Axial Expansion Amount	Lateral Expansion Amount	Design Pressure	Definition
SISKB-50	±50mm	±50mm	16 bar	Double Gimbal Expansion Joint with 50mm lateral expansion,welded end
SISKB-100	±50mm	±100mm	16 bar	Double Gimbal Expansion Joint with 100mm lateral expansion,welded end
SISKB-150	±50mm	±150mm	16 bar	Double Gimbal Expansion Joint with 150mm lateral expansion,welded end
SISKB-200	±50mm	±200mm	16 bar	Double Gimbal Expansion Joint with 200mm lateral expansion,welded end

* Special designed Double Gimbal Expansion Joints with customized features are available on request.

** Subject to technical alterations and deviations resulting from the manufacturing process without giving any notification.

DOUBLE GIMBAL EXPANSION JOINTS

Double Gimbal Expansion Joints, Welded End

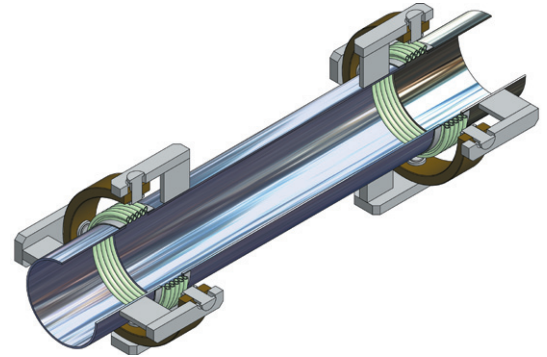
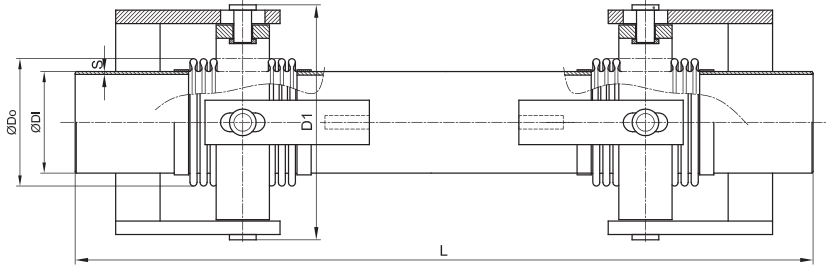

DN	Bellow			D1	s	SISKB-50					SISKB-100				
	ØDi	ØD0	Effective Bellow Area cm ²			Expansion			L	Code	Expansion			L	Code
						± X	± Z	± Y			± X	± Z	± Y		
DN25	38	48,2	14,58	90	2,3	50	50	50	707	702.070.401.002	50	50	100	907	702.070.402.002
DN32	42,2	55	18,62	105	2,6	50	50	50	707	702.070.401.004	50	50	100	907	702.070.402.004
DN40	48,3	61	23,44	115	2,6	50	50	50	707	702.070.401.006	50	50	100	907	702.070.402.006
DN50	60,3	76	36,46	140	2,9	50	50	50	785	702.070.401.008	50	50	100	985	702.070.402.008
DN65	76,1	95	57,45	160	2,9	50	50	50	785	702.070.401.010	50	50	100	958	702.070.402.010
DN80	88,9	111	78,42	190	3,2	50	50	50	815	702.070.401.012	50	50	100	1015	702.070.402.012
DN100	114,3	140	137,09	250	3,6	50	50	50	835	702.070.401.014	50	50	100	1035	702.070.402.014
DN125	139,7	164	181,01	285	4	50	50	50	963	702.070.401.016	50	50	100	1163	702.070.402.016
DN150	168,3	200	266,20	350	4,5	50	50	50	963	702.070.401.018	50	50	100	1163	702.070.402.018
DN200	219,1	250	431,86	420	6,3	50	50	50	1120	702.070.401.020	50	50	100	1320	702.070.402.020
DN250	273	323	697,11	480	6,3	50	50	50	1120	702.070.401.022	50	50	100	1320	702.070.402.022
DN300	323,9	380	972,37	540	7,1	50	50	50	1177	702.070.401.024	50	50	100	1377	702.070.402.024

DN	Bellow			D1	s	SISKB-150					SISKB-200				
	ØDi	ØD0	Effective Bellow Area cm ²			Expansion			L	Code	Expansion			L	Code
						± X	± Z	± Y			± X	± Z	± Y		
DN25	38	48,2	14,58	90	2,3	50	50	150	1107	702.070.403.002	50	50	200	1307	702.070.404.002
DN32	42,2	55	18,62	105	2,6	50	50	150	1107	702.070.403.004	50	50	200	1307	702.070.404.004
DN40	48,3	61	23,44	115	2,6	50	50	150	1107	702.070.403.006	50	50	200	1307	702.070.404.006
DN50	60,3	76	36,46	140	2,9	50	50	150	1185	702.070.403.008	50	50	200	1405	702.070.404.008
DN65	76,1	95	57,45	160	2,9	50	50	150	1235	702.070.403.010	50	50	200	1485	702.070.404.010
DN80	88,9	111	78,42	190	3,2	50	50	150	1255	702.070.403.012	50	50	200	1485	702.070.404.012
DN100	114,3	140	137,09	250	3,6	50	50	150	1285	702.070.403.014	50	50	200	1535	702.070.404.014
DN125	139,7	164	181,01	285	4	50	50	150	1463	702.070.403.016	50	50	200	1763	702.070.404.016
DN150	168,3	200	266,20	350	4,5	50	50	150	1463	702.070.403.018	50	50	200	1763	702.070.404.018
DN200	219,1	250	431,86	420	6,3	50	50	150	1680	702.070.403.020	50	50	200	2030	702.070.404.020
DN250	273	323	697,11	480	6,3	50	50	150	1680	702.070.403.022	50	50	200	2080	702.070.404.022
DN300	323,9	380	972,37	540	7,1	50	50	150	1727	702.070.403.024	50	50	200	2127	702.070.404.024

All the dimensions in the table are given in "mm".