



## **RAPID RESPONSE Series LFII Residential Sprinklers 3.0 K-factor Pendent Wet Pipe Systems**

### **General Description**

The TYCO RAPID RESPONSE Series LFII Residential Pendent Sprinklers (TY1234) are decorative, fast response, frangible bulb sprinklers designed for use in residential occupancies such as homes, apartments, dormitories, and hotels. When aesthetics and optimized flow characteristics are key considerations, the Series LFII (TY1234) should be the first choice.

The 3.0 K-factor of the Series LFII Residential Pendent Sprinkler has been designed to optimize flows (that is, to avoid over discharging) specifically for small coverage areas up to 14 ft. x 14 ft. (4,3 m x 4,3 m). The required residential flow rates can then be delivered with the use of smaller pipe sizes and reduced water supply requirements.

The Series LFII Residential Sprinklers are intended for use in the following scenarios:

- wet pipe residential sprinkler systems for one-and two-family dwellings and mobile homes per NFPA 13D
- wet pipe residential sprinkler systems for residential occupancies up to and including four stories in height per NFPA 13R
- wet pipe sprinkler systems for the residential portions of any occupancy per NFPA 13

The recessed version of the Series LFII Residential Pendent Sprinkler is intended for use in areas with finished ceilings. It employs a two-piece Style 20 Recessed Escutcheon.

The Recessed Escutcheon provides 1/4 inch (6,4 mm) of recessed adjustment or up to 1/2 inch (12,7 mm) of total adjustment from the flush ceiling position. The adjustment provided by the Recessed Escutcheon reduces the accuracy to which the pipe drops to the sprinklers must be cut.

The Series LFII Residential Pendent Sprinkler has been designed with heat sensitivity and water distribution characteristics proven to help in the control of residential fires and to improve the chance for occupants to escape or be evacuated.

#### **NOTICE**

*The Series LFII Residential Pendent Sprinklers (TY1234) described herein must be installed and maintained in compliance with this document and with the applicable standards of the National Fire Protection Association, in addition to the standards of any authorities having jurisdiction. Failure to do so may impair the performance of these devices.*

*The owner is responsible for maintaining their fire protection system and devices in proper operating condition. The installing contractor or sprinkler manufacturer should be contacted with any questions.*



### **Sprinkler Identification Number (SIN)**

TY1234

#### **IMPORTANT**

*Always refer to Technical Data Sheet TFP700 for the "INSTALLER WARNING" that provides cautions with respect to handling and installation of sprinkler systems and components. Improper handling and installation can permanently damage a sprinkler system or its components and cause the sprinkler to fail to operate in a fire situation or cause it to operate prematurely.*

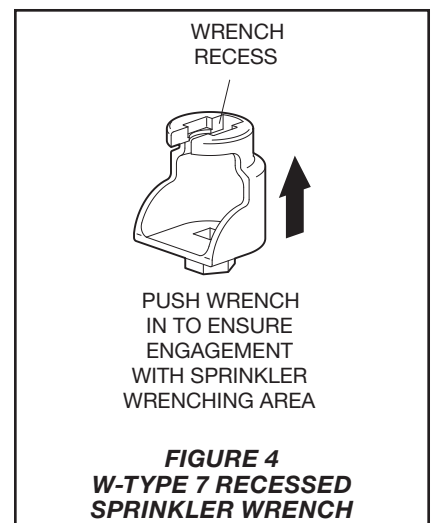
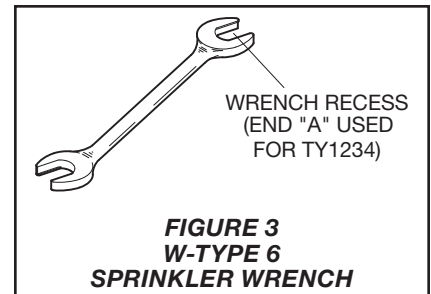
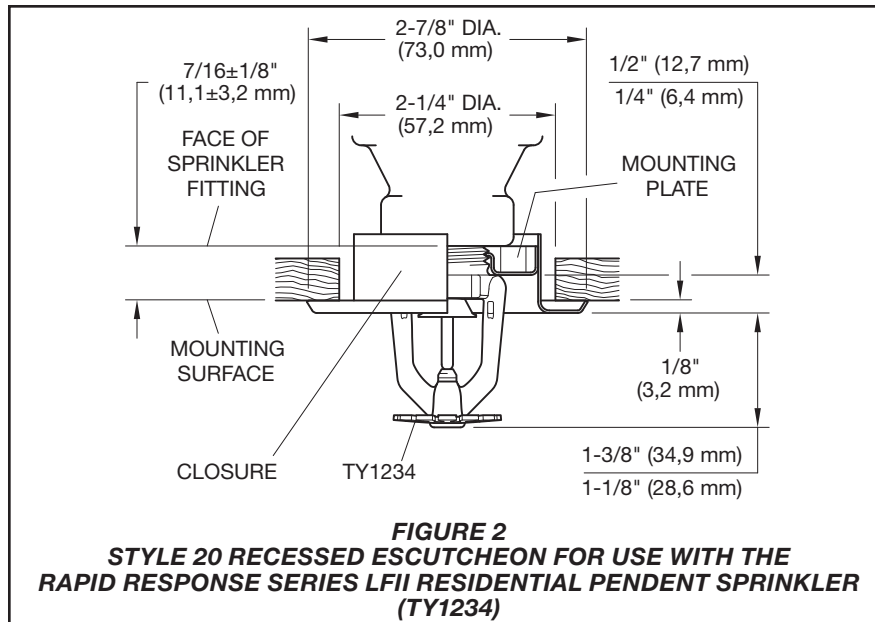
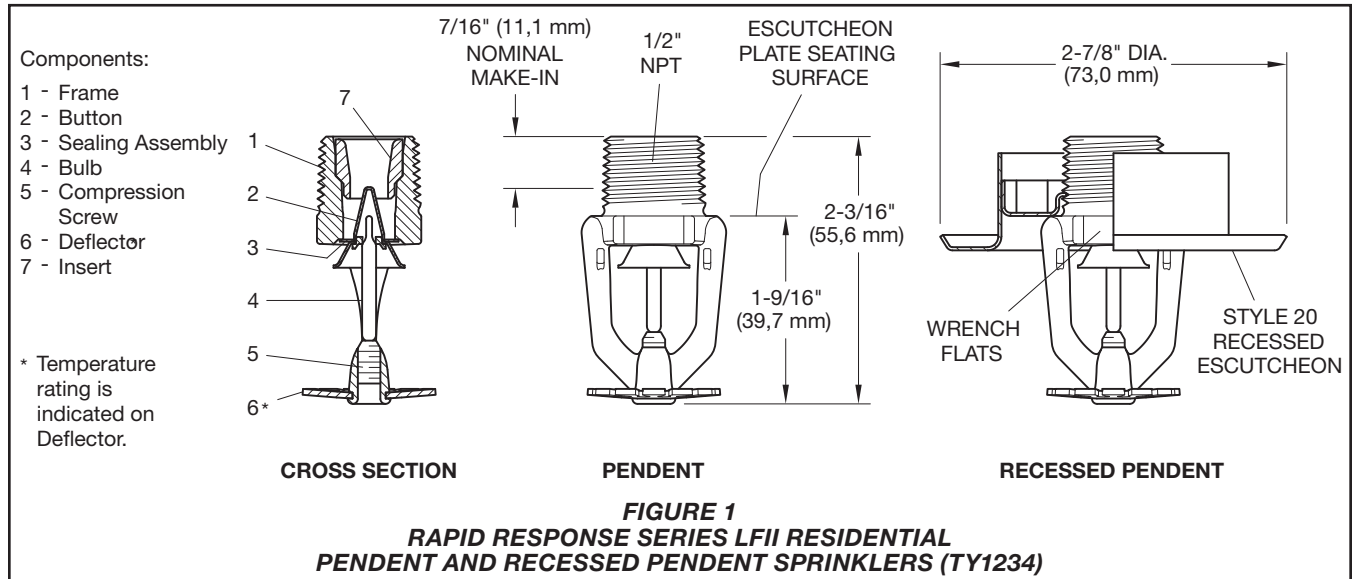

## Technical Data

### Approvals

UL and C-UL Listed  
NSF Certified to NSF/ANSI 61

For details on these approvals, refer to the Design Criteria section.

### Maximum Working Pressure

175 psi (12,1 bar)

### Discharge Coefficient

K=3.0 GPM/psi<sup>1/2</sup> (43,2 LPM/bar<sup>1/2</sup>)

### Temperature Rating

155°F (68°C) or 175°F (79°C)

### Finishes

Natural Brass  
Signal White  
Chrome Plated

### Physical Characteristics

Frame . . . . . Brass  
 Button . . . . . Copper  
 Sealing Assembly . . . . . Beryllium  
    Nickel w/TEFLON  
 Bulb . . . . . 3 mm Glass  
 Compression Screw . . . . . Bronze  
 Deflector . . . . . Bronze

Max. Coverage Area (a) Ft. x Ft. (m x m)	WET PIPE SYSTEM Minimum Flow and Residual Pressure (b, c)					Deflector to Ceiling	Installation Type	Minimum Spacing Ft. (m)
	Ordinary Temp. Rating 155°F (68°C)		Intermediate Temp. Rating 175°F (79°C)					
	Flow GPM (L/min)	Pressure PSI (bar)	Flow GPM (L/min)	Pressure PSI (bar)				
12 x 12 (3,7 x 3,7)	8 (30,3)	7.1 (0,49)	8 (30,3)	7.1 (0,49)	Smooth Ceilings 1-1/4 to 4 inches	Recessed using Style 20 Escutcheon or non-recessed per NFPA 13D, 13R, or 13	8 (2,4)	
14 x 14 (4,3 x 4,3)	11 (41,6)	13.4 (0,92)	11 (41,6)	13.4 (0,92)	Beamed Ceilings per NFPA 13D or 13R 1-1/4 to 1-3/4 inches below bottom of beam.			
16 x 16 (4,9 x 4,9)	13 (49,2)	18.8 (1,29)	13 (49,2)	18.8 (1,29)				
18 x 18 (5,5 x 5,5)	17 (64,3)	32,1 (2,21)	18 (68,1)	36.0 (2,48)				

- (a) For coverage area dimensions less than or between those indicated, use the minimum required flow for the next highest coverage area for which hydraulic design criteria are stated.
- (b) Requirement is based on minimum flow in GPM (LPM) from each sprinkler. The associated residual pressures are calculated using the nominal K-factor. Refer to Hydraulic Design under the Design Criteria section.
- (c) For NFPA 13 residential applications, the greater of 0.1 gpm/ft<sup>2</sup> over the design area or the flow in accordance with the criteria in this table must be used.

**TABLE A**  
**WET PIPE SYSTEM**  
**SERIES LFII RESIDENTIAL PENDENT AND RECESSED PENDENT SPRINKLERS (TY1234)**  
**NFPA 13D, 13R, AND 13 HYDRAULIC DESIGN CRITERIA**

## Operation

The glass bulb contains a fluid that expands when exposed to heat. When the rated temperature is reached, the fluid expands sufficiently to shatter the glass bulb, allowing the sprinkler to activate and flow water.

## Design Criteria

The TYCO RAPID RESPONSE Series LFII Residential Pendent Sprinklers (TY1234) are UL and C-UL Listed for installation in accordance with the following criteria.

### Residential Sprinkler Design Guide

When conditions exist that are outside the scope of the provided criteria, refer to the Residential Pendent Sprinkler Design Guide TFP490 for the manufacturer's recommendations that may be acceptable to the local authority having jurisdiction.

### System Type

Only wet pipe systems may be utilized.

### Ceiling Types

Smooth flat horizontal, or beamed, or sloped, in accordance with the 2013 Edition of NFPA 13D, 13R, or 13 as applicable.

### Hydraulic Design (NFPA 13D and 13R)

The minimum required sprinkler flow rate for systems designed to NFPA 13D or NFPA 13R are given in Table A as a function of temperature rating and the maximum allowable coverage areas. The sprinkler flow rate is the minimum required discharge from each of the total number of design sprinklers as specified in NFPA 13D or NFPA 13R.

### Hydraulic Design (NFPA 13)

For systems designed to NFPA 13, the number of design sprinklers is to be the four most hydraulically demanding sprinklers. The minimum required discharge from each of the four sprinklers is to be the greater of the following:

- The flow rates given in Table A for NFPA 13D and 13R as a function of TFP402 temperature rating and the maximum allowable coverage area.
- A minimum discharge of 0.1 gpm/ft.<sup>2</sup> over the "design area" comprised of the four most hydraulically demanding sprinklers for actual coverage areas protected by the four sprinklers.

### Obstruction to Water Distribution

Sprinklers are to be located in accordance with the obstruction rules of NFPA 13D, 13R, and 13 as applicable for residential sprinklers as well as

with the obstruction criteria described within the TYCO technical data sheet TFP490.

### Operational Sensitivity

Sprinklers are to be installed with a deflector-to-ceiling distance of 1-1/4 to 4 inches.

### Sprinkler Spacing

The minimum spacing between sprinklers is 8 feet (2,4 m). The maximum spacing between sprinklers cannot exceed the length of the coverage area being hydraulically calculated (e.g., a maximum of 12 feet for a 12 ft. x 12 ft. coverage area, or 16 feet for a 16 ft. x 16 ft. coverage area.) Refer to Table A.

## Installation

The TYCO RAPID RESPONSE Series LFII Residential Pendent Sprinklers (TY1234) must be installed in accordance with this section:

### General Instructions

Do not install any bulb-type sprinkler if the bulb is cracked or there is a loss of liquid from the bulb. With the sprinkler held horizontally, a small air bubble should be present. The diameter of the air bubble is approximately 1/16 inch (1,6 mm).

A leak-tight 1/2 inch NPT sprinkler joint should be obtained by applying a minimum-to-maximum torque of 7 to 14 ft.-lbs. (9,5 to 19,0 Nm). Higher levels of torque can distort the sprinkler inlet with consequent leakage or impairment of the sprinkler.

Do not attempt to compensate for insufficient adjustment in an Escutcheon Plate by under-or over-tightening the Sprinkler. Re-adjust the position of the sprinkler fitting to suit.

### Series LFII Residential Pendent Sprinklers

The Series LFII Residential Pendent Sprinklers must be installed in accordance with the following instructions.

**Step 1.** Install pendent sprinklers in the pendent position with the deflector parallel to the ceiling.

**Step 2.** With pipe-thread sealant applied to the pipe threads, hand-tighten the sprinkler into the sprinkler fitting.

**Step 3.** Wrench-tighten the sprinkler into the sprinkler fitting using only the W-Type 6 Sprinkler Wrench (Figure 3). With reference to Figure 1, apply the W-Type 6 Sprinkler Wrench to the wrench flats.

### Series LFII Residential Recessed Pendent Sprinklers

The Series LFII Recessed Pendent Sprinklers must be installed in accordance with the following instructions.

**Step A.** Install recessed pendent sprinklers in the pendent position with the deflector parallel to the ceiling.

**Step B.** After installing the Style 20 Mounting Plate over the sprinkler threads and with pipe thread sealant applied to the pipe threads, hand-tighten the sprinkler into the sprinkler fitting.

**Step C.** Wrench-tighten the sprinkler into the sprinkler fitting using only the W-Type 7 Recessed Sprinkler Wrench (Figure 4). With reference to Figure 1, apply the W-Type 7 Recessed Sprinkler Wrench to the sprinkler wrench flats.

**Step D.** After installing the ceiling applying the finish coat, slide on the Style 20 Closure over the Series LFII Sprinkler and push the Closure over the Mounting Plate until the flange comes in contact with the ceiling.

## Care and Maintenance

The TYCO RAPID RESPONSE Series LFII Residential Pendent Sprinklers (TY1234) must be maintained and serviced in accordance with this section:

Before closing a fire protection system main control valve for maintenance work on the fire protection system that it controls, obtain permission to shut down the affected fire protection system from the proper authorities and notify all personnel who may be affected by this decision.

Absence of the outer piece of an escutcheon, which is used to cover a clearance hole, can delay sprinkler operation in a fire situation.

The owner must assure that the sprinklers are not used for hanging any objects and that the sprinklers are only cleaned by means of gently dusting with a feather-duster. Otherwise, non-operation in the event of a fire or inadvertent operation may result.

Sprinklers which are found to be leaking or exhibiting visible signs of corrosion must be replaced.

Automatic sprinklers must never be painted, plated, coated, or otherwise altered after leaving the factory. Modified sprinklers must be replaced. Sprinklers that have been exposed to corrosive products of combustion, but have not operated, should be replaced if they cannot be completely cleaned by wiping the sprinkler with a cloth or by brushing it with a soft bristle brush.

Care must be exercised to avoid damage to the sprinklers - before, during, and after installation. Sprinklers damaged by dropping, striking, wrench twist/slippage, or the like, must be replaced. Also, replace any sprinkler that has a cracked bulb or that has lost liquid from its bulb. (Ref. Installation Section.)

The owner is responsible for the inspection, testing, and maintenance of their fire protection system and devices in compliance with this document, as well as with the applicable standards of the National Fire Protection Association (e.g., NFPA 25), in addition to the standards of any other authorities having jurisdiction. Contact the installing contractor or sprinkler manufacturer regarding any questions.

Automatic sprinkler systems are recommended to be inspected, tested, and maintained by a qualified Inspection Service in accordance with local requirements and/or national codes.

## Ordering Procedure

Contact your local distributor for availability. When placing an order, indicate the full product name and Part Number (P/N).

### Sprinkler Assembly

Specify: Series LFII (TY1234), K=3.0, Residential Pendent Sprinkler, (specify) temperature rating, (specify) finish, and P/N (specify).

#### 155°F (68°C)

Natural Brass .....P/N 51-010-1-155  
Signal White (RAL 9003). ....P/N 51-010-4-155  
Chrome Plated .....P/N 51-010-9-155

#### 175°F (79°C)

Natural Brass .....P/N 51-010-1-175  
Signal White (RAL 9003). ....P/N 51-010-4-175  
Chrome Plated .....P/N 51-010-9-175

### Recessed Escutcheon

Specify: Style 20 Recessed Escutcheon with (specify\*) finish, and P/N (specify\*).

\*Refer to Technical Data Sheet TFP770.

### Sprinkler Wrench

Specify: W-Type 6 Sprinkler Wrench for use with Series LFII Pendent Sprinklers, P/N 56-000-6-387.

Specify: W-Type 7 Sprinkler Wrench for use with Series LFII Recessed Pendent Sprinklers, P/N 56-850-4-001.