

RAPID RESPONSE Series LFII Residential Sprinklers 4.9 K-factor Domed-Plate Concealed Pendent Wet Pipe and Dry Pipe Systems

General Description

The TYCO RAPID RESPONSE Series LFII Residential Domed-Plate Concealed Pendent 4.9 K-factor Sprinklers (TY2234) are decorative, fast response, frangible bulb sprinklers designed for use in residential occupancies such as homes, apartments, dormitories, and hotels.

The Cover Plate/Retainer Assembly conceals the sprinkler operating components above the ceiling. The domed profile of the cover plate provides aesthetically appealing sprinkler design with lower flow rates than can be achieved by lower profile cover plates. The separable two-piece design of the Cover Plate and Support Cup Assemblies allows installation of the sprinklers and pressure testing of the fire protection system prior to the installation of the ceiling or application of a finish coating.

Also, the separable “push-on and thread-off” two-piece design of the Sprinkler provides for 1/2 inch (12,7 mm) of vertical adjustment.

The Series LFII Residential Sprinklers (TY2234) are intended for use in the following scenarios:

- wet and dry pipe residential sprinkler systems for one- and two-family dwellings and mobile homes per NFPA 13D
- wet and dry pipe residential sprinkler systems for residential occupancies up to and including four stories in height per NFPA 13R

IMPORTANT

Always refer to Technical Data Sheet TFP700 for the “INSTALLER WARNING” that provides cautions with respect to handling and installation of sprinkler systems and components. Improper handling and installation can permanently damage a sprinkler system or its components and cause the sprinkler to fail to operate in a fire situation or cause it to operate prematurely.

- wet and dry pipe sprinkler systems for the residential portions of any occupancy per NFPA 13

The Series LFII Residential Sprinklers have been designed with heat sensitivity and water distribution characteristics proven to help in the control of residential fires and to improve the chance for occupants to escape or be evacuated.

The Series LFII Residential Domed-Plate Concealed Pendent Sprinklers (TY2234) are shipped with a Disposable Protective Cap. The Protective Cap is temporarily removed for installation, and it must be replaced to protect the sprinkler while the ceiling is being installed or finished. The tip of the Protective Cap can also be used to mark the center of the ceiling hole into plaster board or ceiling tiles by gently pushing the ceiling product against the Protective Cap. When ceiling installation is complete, the Protective Cap must be removed and the Cover Plate Assembly installed. The Protective Cap must be removed to ensure proper performance of the sprinklers.

Dry Pipe System Application

The Series LFII Residential Domed-Plate Concealed Pendent Sprinklers (TY2234) Listing offers a laboratory approved option for designing dry pipe residential sprinkler systems, whereas, most residential sprinklers are laboratory approved for wet systems only.

Through extensive testing, it has been determined that the number of design sprinklers (hydraulic design area) for the Series LFII Residential Domed-Plate Concealed Pendent Sprinklers (TY2234) need not be increased over the number of design sprinklers (hydraulic design area) as specified for wet pipe sprinkler systems, as is customary for density/area sprinkler systems designed per NFPA 13.

Consequently, the Series LFII Residential Domed-Plate Concealed Pendent Sprinklers offer the features of non-water filled pipe in addition to not having to increase the number of design sprinklers (hydraulic design area) for systems designed to NFPA 13, 13D, or 13R. Non-water filled pipe will permit options for areas sensitive to freezing.



NOTICE

The Series LFII Residential Domed-Plate Concealed Pendent Sprinklers (TY2234) described herein must be installed and maintained in compliance with this document and the applicable standards of the National Fire Protection Association, in addition to the standards of any authorities having jurisdiction. Failure to do so may impair the performance of these devices.

The owner is responsible for maintaining their fire protection system and devices in proper operating condition. Contact the installing contractor or sprinkler manufacturer with any questions.

Sprinkler Identification Number (SIN)

TY2234

Technical Data

Approvals

UL Listed for use with wet pipe and dry pipe systems

C-UL Listed for use only with wet pipe systems

NYC Approved under MEA 44-03-E

The Series LFII Residential Domed-Plate Concealed Pendent Sprinklers are only listed with the Series LFII Residential Domed-Plate Concealed Pendent Cover Plates having a factory applied finish.

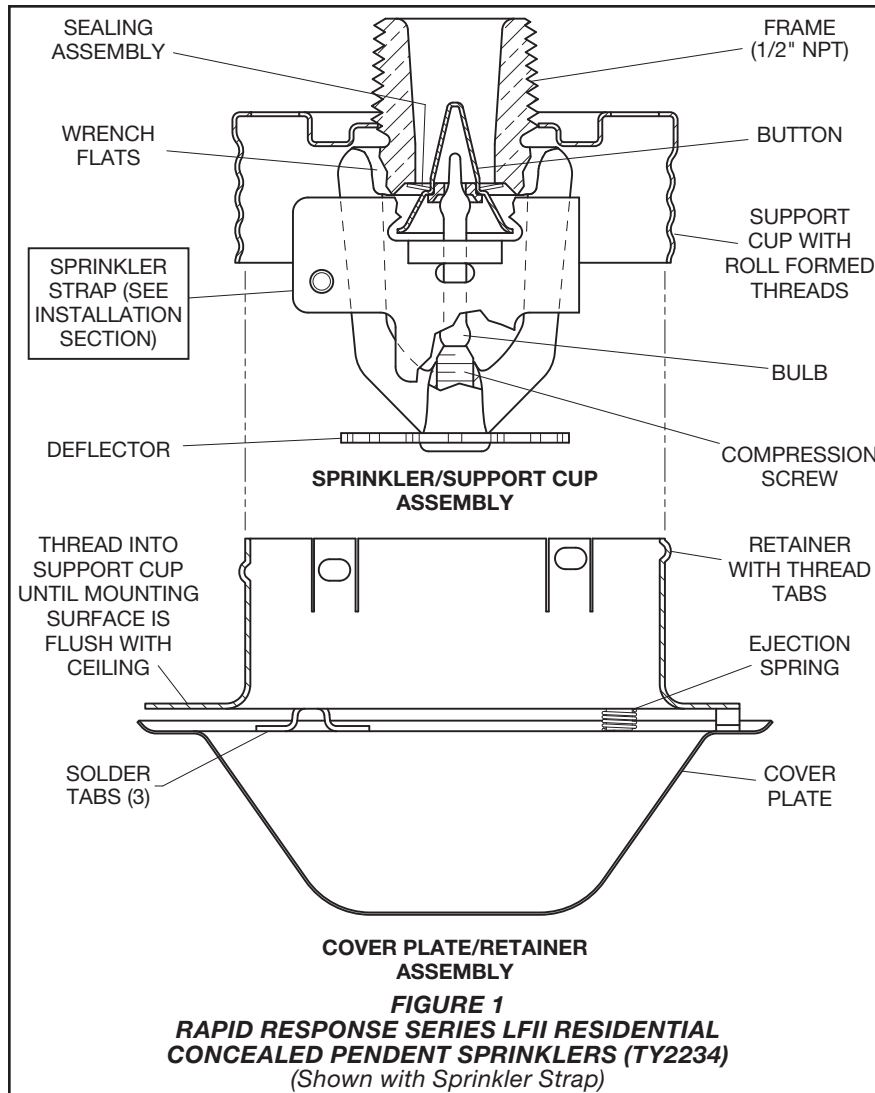

FIGURE 1
RAPID RESPONSE SERIES LFII RESIDENTIAL
CONCEALED PENDENT SPRINKLERS (TY2234)
(Shown with Sprinkler Strap)

For details on these approvals, refer to the Design Criteria section.

All listed cover plates and corresponding part numbers having factory applied finishes can be found in the Ordering Procedure section of this data sheet.

Maximum Working Pressure
175 psi (12,1 bar)

Discharge Coefficient
K = 4.9 GPM/psi^{1/2} (70,6 LPM/bar^{1/2})

Temperature Rating
155°F (68°C) Sprinkler with
139°F (59°C) Cover Plate

Vertical Adjustment
1/2 inch (12,7 mm)

Finishes
Refer to Ordering Procedure section.

Physical Characteristics

Frame	Brass
Button	Bronze
Sealing Assembly	Beryllium
	Nickel w/ TEFLON
Bulb (3 mm)	Glass
Compression Screw	Brass
Deflector	Copper
Button Ejection Spring	Stainless Steel
Support Cup	Steel
Cover Plate	Brass
Retainer	Brass
Cover Plate Ejection Spring	Stainless Steel

Operation

When exposed to heat from a fire, the Cover Plate, which is normally soldered to the Support Cup at three points, falls away to expose the Sprinkler Assembly. The glass bulb contains a fluid that expands when exposed to heat. When the rated temperature is reached, the fluid expands sufficiently to shatter the glass bulb allowing the sprinkler to activate and flow water.

Design Criteria

The TYCO RAPID RESPONSE Series LFII Residential Domed-Plate Concealed Pendent 4.9 K-factor Sprinklers (TY2234) are UL and C-UL Listed for installation in accordance with this section.

Residential Sprinkler Design Guide

When conditions exist that are outside the scope of the provided criteria, refer to the Residential Sprinkler Design Guide TFP490 for the manufacturer's recommendations that may be acceptable to the authority having jurisdiction.

System Types

Per the UL Listing, wet pipe and dry pipe systems may be utilized. Per the C-UL Listing, only wet pipe systems may be utilized.

Refer to Technical Data Sheet TFP485 about the use of Residential Sprinklers in residential dry pipe systems.

Ceiling Types

Smooth flat horizontal, or beamed, or sloped, in accordance with the 2013 Edition of NFPA 13D, 13R, or 13 as applicable.

Hydraulic Design (NFPA 13D and 13R)

For systems designed to NFPA 13D or NFPA 13R, the minimum required sprinkler flow rate are given in Tables A and B as a function of temperature rating and the maximum allowable coverage areas. The sprinkler flow rate is the minimum required discharge from each of the total number of "design sprinklers" as specified in NFPA 13D or NFPA 13R. The number of "design sprinklers" specified in NFPA 13D and 13R for wet pipe systems is to be applied when designing dry pipe systems.

Hydraulic Design (NFPA 13)

For systems designed to NFPA 13, the number of design sprinklers is to be the four most hydraulically demanding sprinklers. The minimum required discharge from each of the four sprinklers is to be the greater of the following:

- The flow rates given in Tables A and B as a function of temperature rating and the maximum allowable coverage area.
- A minimum discharge of 0.1 gpm/ft², over the "design area" comprised of the four most hydraulically demanding sprinklers for the actual coverage areas being protected by the four sprinklers.

Maximum Coverage Area ^a Ft. x Ft. (m x m)	Maximum Spacing Ft. (m)	WET PIPE SYSTEM Minimum Flow and Residual Pressure ^{b, c}				
		Ordinary Temp. Rating 155°F (68°C)		Deflector to Ceiling	Installation Type	Minimum Spacing Ft. (m)
		Flow GPM (L/min)	Pressure PSI (bar)			
12 x 12 (3,7 x 3,7)	12 (3,7)	13 (49,2)	7.0 (0,48)	Smooth Ceilings 1/4 to 3/4 inches Beamed Ceilings per NFPA 13D or 13R Installed in Beam 1/4 to 3/4 inches below bottom of beam	Concealed	8 (2,4)
14 x 14 (4,3 x 4,3)	14 (4,3)	13 (49,2)	7.0 (0,48)			
16 x 16 (4,9 x 4,9)	16 (4,9)	13 (49,2)	7.0(0,48)			
18 x 18 (5,5 x 5,5)	18 (5,5)	17 (64,3)	12.0 (0,83)			
20 x 20 (6,1 x 6,1)	20 (6,1)	20 (75,7)	16.7 (1,15)			

- a. For coverage area dimensions less than or between those indicated, use the minimum required flow for the next highest coverage area for which hydraulic design criteria are stated.
- b. Requirement is based on minimum flow in GPM (LPM) from each sprinkler. The associated residual pressures are calculated using the nominal K-factor. Refer to Hydraulic Design under the Design Criteria section.
- c. For NFPA 13 residential applications, the greater of 0.1 gpm/ft.² over the design area or the flow in accordance with the criteria in this table must be used.

TABLE A
WET PIPE SYSTEMS
SERIES LFII RESIDENTIAL DOMED-PLATE CONCEALED PENDENT SPRINKLERS (TY2234)
NFPA 13D, 13R, AND 13 HYDRAULIC DESIGN CRITERIA

Maximum Coverage Area ^a Ft. x Ft. (m x m)	Maximum Spacing Ft. (m)	DRY PIPE SYSTEM Minimum Flow and Residual Pressure ^{b, c}				
		Ordinary Temp Rating 155°F (71°C)		Deflector to Ceiling	Installation Type	Minimum Spacing Ft. (m)
		Flow GPM (L/min)	Pressure PSI (bar)			
12 x 12 (3,7 x 3,7)	12 (3,7)	13 (49,2)	7.0 (0,48)	Smooth Ceilings 1/4 to 3/4 inches Beamed Ceilings per NFPA 13D or 13R Installed in Beam 1/4 to 3/4 inches below bottom of beam	Concealed	8 (2,4)
14 x 14 (4,3 x 4,3)	14 (4,3)	14 (53,0)	8.2 (0,57)			
16 x 16 (4,9 x 4,9)	16 (4,9)	15 (56,8)	9.4 (0,65)			
18 x 18 (5,5 x 5,5)	18 (5,5)	20 (75,7)	16.7 (1,15)			
20 x 20 (6,1 x 6,1)	20 (6,1)	22 (83,3)	20.2 (1,39)			

- a. For coverage area dimensions less than or between those indicated, use the minimum required flow for the next highest coverage area for which hydraulic design criteria are stated.
- b. Requirement is based on minimum flow in GPM (LPM) from each sprinkler. The associated residual pressures are calculated using the nominal K-factor. Refer to Hydraulic Design under the Design Criteria section.
- c. For NFPA 13 residential applications, the greater of 0.1 gpm/ft.² over the design area or the flow in accordance with the criteria in this table must be used.

TABLE B
DRY PIPE SYSTEM
SERIES LFII RESIDENTIAL DOMED-PLATE CONCEALED PENDENT SPRINKLERS (TY2234)
NFPA 13D, 13R, AND 13 HYDRAULIC DESIGN CRITERIA

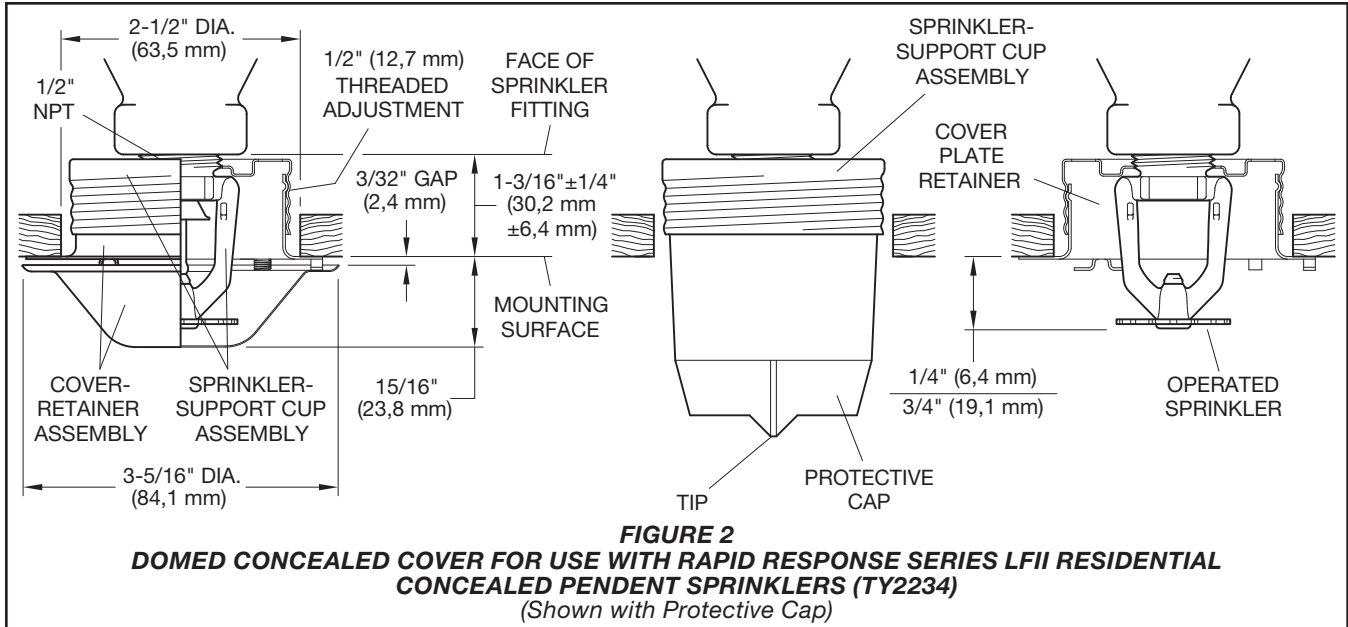

The number of “design sprinklers” specified in NFPA 13D and 13R for wet pipe systems is to be applied when designing dry pipe systems.

Dry Pipe System Water Delivery

When using the Series LFII Residential Pendent Sprinklers (TY2234) in dry pipe sprinkler systems, the time for water delivery must not exceed 15 seconds for the most remote operating sprinkler.

Obstruction to Water Distribution
Sprinklers are to be located in accordance with the obstruction rules of NFPA 13D, 13R, and 13 as applicable for residential sprinklers as well as with the obstruction criteria described within the Technical Data Sheet TFP490.

Operational Sensitivity

The sprinklers are to be installed relative to the ceiling mounting surface as shown in Figure 2.

The Series LFII Residential Domed-Plate Concealed Pendent Sprinklers must not be used in applications where the air pressure above the ceiling is greater than that below. Down drafts through the Support Cup could delay sprinkler operation in a fire situation.

Sprinkler Spacing

The minimum spacing between sprinklers is 8 feet (2,4 m). The maximum spacing between sprinklers cannot exceed the length of the coverage area (Table A or B) being hydraulically calculated (e.g., maximum 12 feet for a 12 ft. x 12 ft. coverage area, or 20 feet for a 20 ft. x 20 ft. coverage area).

Installation

The TYCO RAPID RESPONSE Series LFII Residential Domed-Plate Concealed Pendent 4.9 K-factor Sprinklers (TY2234) must be installed in accordance with this section.

General Instructions

Do not install any bulb type sprinkler if the bulb is cracked or there is a loss of liquid from the bulb. With the sprinkler held horizontally, a small air bubble should be present. The diameter of the air bubble is approximately 1/16 inch (1,6 mm).

A leak-tight 1/2 inch NPT sprinkler joint should be obtained by applying a minimum-to-maximum torque of 7 to 14 ft.-lbs. (9,5 to 19,0 Nm). Higher levels of torque can distort the sprinkler Inlet with consequent leakage or impairment of the sprinkler.

Do not attempt to compensate for insufficient adjustment in an Escutcheon Plate by under- or over-tightening the Sprinkler. Re-adjust the position of the sprinkler fitting to suit.

Step 1. Install the sprinkler in the pendent position and with the centerline of the sprinkler perpendicular to the mounting surface.

Step 2. Remove the Protective Cap. Refer to NFPA 13 for guidance regarding removal of protective straps and caps

Step 3. With pipe thread sealant applied to the pipe threads, and using the W-Type 7 Wrench shown in Figure 3, install and tighten the Sprinkler/Support Cup Assembly into the fitting. The W-Type 7 Wrench will accept a 1/2 inch ratchet drive.

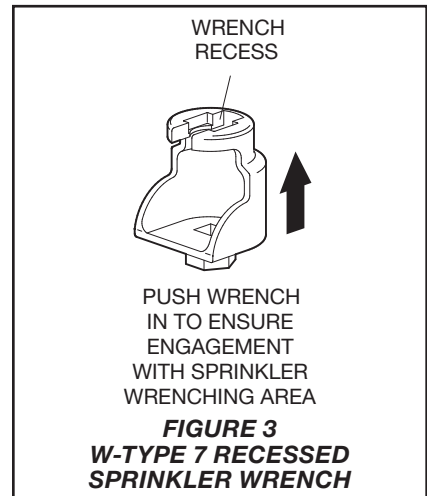

Step 4. Replace the Protective Cap by pushing it upwards until it bottoms out against the Support Cup. The Protective Cap helps prevent damage to the Deflector and Arms during ceiling installation and/or during application of the finish coating of the ceiling. It may also be used to locate the center of the clearance hole by gently pushing the ceiling material against the center point of the Cap.

As long as the Sprinkler Strap (Figure 1) or the Protective Cap (Figure 2) remains in place, the system is considered to be “Out Of Service.”

Step 5. After the ceiling has been completed with the 2-1/2 inch (63 mm) diameter clearance hole and in preparation for installing the Cover Plate/Retainer Assembly, remove and discard the Protective Cap and the Sprinkler Strap.

NOTE: Refer to Technical Data Sheet TFP700 regarding instructions for the removal of the Sprinkler Strap.

Step 6. Push the Cover Plate/Retainer Assembly into the Support Cup, and as necessary, make the final adjustment of the Cover Plate with respect to the ceiling by turning the Cover Plate/Retainer Assembly clockwise until its flange just comes in contact with the ceiling.

If it becomes necessary to remove the Cover Plate, it can be removed by unscrewing in a counter-clockwise direction.

If the Cover Plate/Retainer Assembly cannot be engaged with the Support Cup or the Cover Plate/Retainer Assembly cannot be engaged sufficiently to contact the ceiling, the Sprinkler Fitting must be repositioned.

Care and Maintenance

The TYCO RAPID RESPONSE Series LFII Residential Domed-Plate Concealed Pendent 4.9 K-factor Sprinklers (TY2234) must be maintained and serviced in accordance with this section.

Before closing a fire protection system main control valve for maintenance work on the fire protection system that it controls, obtain permission to shut down the affected fire protection systems from the proper authorities and notify all personnel who may be affected by this action.

Absence of a Cover Plate may delay sprinkler operation in a fire situation.

The owner must assure that the sprinklers are not used for hanging any objects and that the sprinklers are only cleaned by means of gently dusting with a feather duster; otherwise, non-operation in the event of a fire or inadvertent operation may result.

When properly installed, there is a nominal 3/32 inch (2,4 mm) air gap between the lip of the Cover Plate and the ceiling, as shown in Figure 2. This air gap is necessary for proper operation of the sprinkler by allowing heat flow from a fire to pass below and above the Cover Plate to help assure appropriate release of the Cover Plate in a fire situation. If the ceiling needs repainting after sprinkler installation, exercise care to ensure that the new paint does not seal off any of the air gap. Failure to do so may impair sprinkler operation.

Factory painted Cover Plates must not be repainted. They should be replaced, if necessary, by factory painted units. Non-factory applied paint may adversely delay or prevent sprinkler operation in the event of a fire.

Do not pull the Cover Plate relative to the Retainer. Separation may result.

Sprinklers which are found to be leaking or exhibiting visible signs of corrosion must be replaced.

Automatic sprinklers must never be painted, plated, coated, or otherwise altered after leaving the factory. Modified or overheated sprinklers must be replaced.

Care must be exercised to avoid damage to the sprinklers - before, during, and after installation. Sprinklers damaged by dropping, striking, wrench twist/slippage, or the like, must be replaced. Also, replace any sprinkler that has a cracked bulb or that has lost liquid from its bulb. (Ref. Installation Section.)

The owner is responsible for the inspection, testing, and maintenance of their fire protection system and devices in compliance with this document, as well as with the applicable standards of the National Fire Protection Association (e.g., NFPA 25), in addition to the standards of any authorities having jurisdiction. Contact the installing contractor or sprinkler manufacturer regarding any questions.

Automatic sprinkler systems are recommended to be inspected, tested, and maintained by a qualified Inspection Service in accordance with local requirements and/or national codes.

Limited Warranty

For warranty terms and conditions, visit www.tyco-fire.com.

Ordering Procedure

Contact your local distributor for availability. When placing an order, indicate the full product name and Part Number (P/N).

Sprinkler Assembly

Specify: Series LFII (TY2234), K = 4.9, Residential Domed-Plate Concealed Pendent Sprinkler without Cover Plate Assembly, P/N 51-873-1-155

Cover Plate Assembly

Specify: Series LFII (TY2234), K = 4.9, Residential Domed-Plate Concealed Pendent Sprinkler Cover Plate Assembly with (specify) finish, P/N (specify):

Pure White* (RAL9010) P/N 56-873-3-135
Signal White (RAL9003) P/N 56-873-4-135
Chrome P/N 56-873-9-135
Custom P/N 56-873-X-135

* Eastern Hemisphere sales only.

Sprinkler Wrench

Specify: W-Type 7 Sprinkler Wrench, P/N 56-850-4-001