

# YSG175. Y Type Strainer - Grooved

UL Listed

## Pressure and Temperature

Nominal Pressure	12 Bar
Hydraulic Shell Test Pressure	24 Bar
Pressure / Temperature Ratings	12 Bar from -10 °C ~ 120 °C
Suitable Media	Water, Oil, Gas

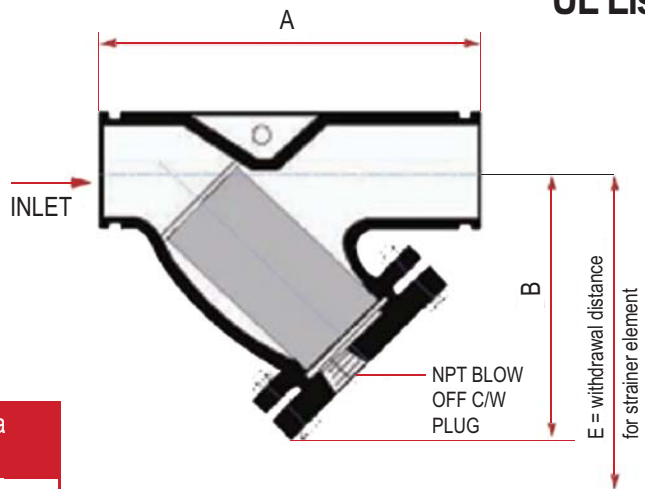

## Standard Screens

Nominal Size (mm)	Hole Dia (mm)	Free Flow Area (%)
65	2.54	37.4
80-200	4.70	46.0
250	4.70	51.0
300	6.30	58.0

## Dimensions

Nominal Size (mm)	Pipe OD (mm)	A (mm)	B (mm)	E (mm)	Blow Off BSP / NPT (mm)	Weight Kg
65	73.0	285	196	238	25.4	11.0
65	76.1	285	196	238	25.4	11.0
80	88.9	318	219	260	25.4	18.0
100	114.3	375	254	325	38.1	26.0
150	165.1	502	365	508	50.8	65.0
150	168.3	502	365	508	50.8	65.0
200	219.1	640	462	575	50.8	113.0
250	273.0	710	540	750	50.8	196.0
300	323.9	780	610	899	50.8	242.0

## Material Specification

Component	Material
Body	Ductile Iron ASTM A536 70-50-05A
Cover	Ductile Iron ASTM A536 70-50-05A
Screen	Stainless Steel AISI 304
Gasket	PTFE / Graphite
Plug	Ductile Iron ASTM A536 70-50-05

## Note

1. Grooved joint-dimensions are made in accordance to metric and ANSI standard pipe sizes.
2. Pressure and temperature ratings are for grooved couplings of an equivalent pressure ratings.
3. Design and materials are subject to change without notice.